

FEATURES

- 200 MHz ARM920T Processor
 - 16 Kbyte Instruction Cache
 - 16 Kbyte Data Cache
 - Linux®, Microsoft® Windows® CE enabled MMU
 - 100 MHz System Bus
- MaverickCrunch™ Math Engine
 - Floating point, integer and signal processing instructions
 - Optimized for digital music compression and decompression algorithms
 - Hardware interlocks allow in-line coding
- MaverickKey™ IDs
 - 32-bit unique ID can be used for DRM compliance
 - 128-bit random ID
- Integrated Peripheral Interfaces
 - 32-bit SDRAM Interface up to 4 banks
 - 32/16-bit SRAM / FLASH / ROM
 - Serial EEPROM Interface
 - EIDE (up to 2 devices)
 - 1/10/100 Mbps Ethernet MAC
 - Three UARTs
 - Three-port USB 2.0 Full Speed Host (OHCI) (12 Mbits per second)
 - IrDA Interface
 - LCD and Raster Interface with Graphics

Enhanced Universal Platform System-on-Chip Processor

- Accelerator
 - PCMCIA Interface
 - Touchscreen Interface with ADC
 - 8 x 8 Keypad Scanner
 - One Serial Peripheral Interface (SPI) Port
 - 6-channel or 2-channel Serial Audio Interface (I²S)
 - 2-channel low-cost Serial Audio Interface (AC'97)
 - 2 High Resolution PWM (16 bits each)
- Internal Peripherals
 - 12 Direct Memory Access (DMA) Channels
 - Real-time Clock with software Trim
 - Dual PLL controls all clock domains
 - Watchdog Timer
 - Two general purpose 16-bit timers
 - One general purpose 32-bit timer
 - One 40-bit Debug Timer
 - Interrupt Controller
 - Boot ROM
- Package
 - 352 pin PBGA

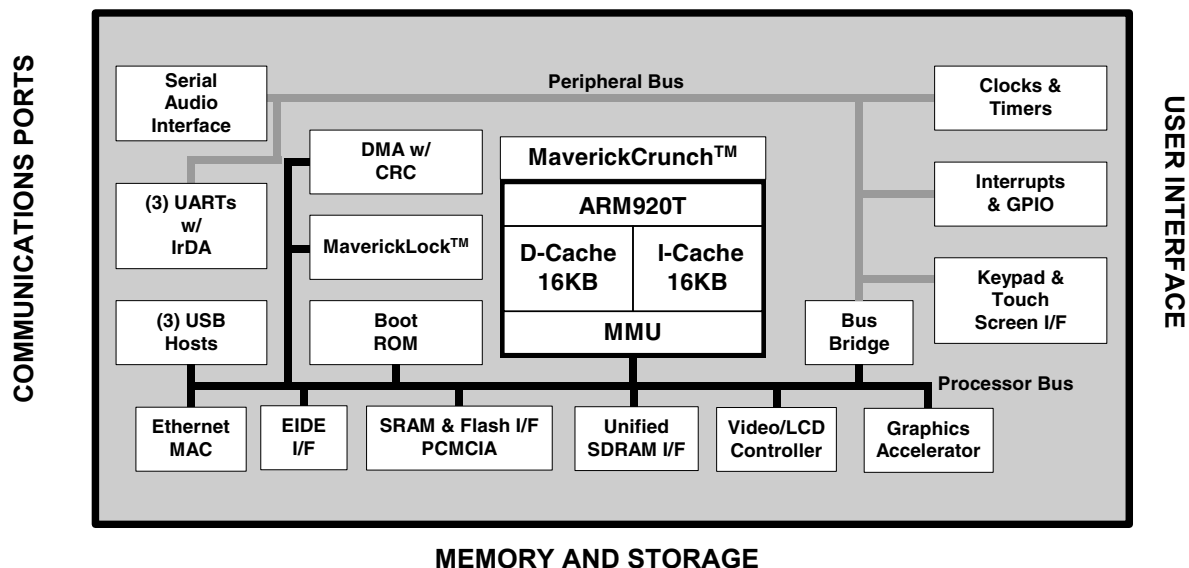

OVERVIEW

The EP9315 is an ARM920T-based system-on-a-chip design with a large peripheral set targeted to a variety of applications:

- Thin client computers for business and home
- Internet radio
- Internet access devices
- Industrial computers
- Specialized terminals
- Point of sale terminals
- Test and measurement equipment

The EP9315 is the senior member of a series of ARM920T-based devices.

The ARM920T microprocessor core with separate 16 Kbyte, 64-way set-associative instruction and data caches is augmented by the MaverickCrunch™ co-processor, enabling high speed floating point calculations.

MaverickKey™ unique hardware programmed IDs are a solution to the growing concern over secure web content

and commerce. With Internet security playing an important role in the delivery of digital media such as books or music, traditional software methods are quickly becoming unreliable. The MaverickKey unique IDs provide OEMs with a method of utilizing specific hardware IDs such as those assigned for SDMI (Secure Digital Music Initiative) or any other authentication mechanism.

A high-performance 1/10/100 Mbps Ethernet Media Access Controller (EMAC) is included along with external interfaces to SPI, I²S audio, Raster/LCD, IDE storage peripherals, keypad, and touchscreen. A three-port USB 2.0 Full Speed Host (OHCI) (12 Mbits per second) and three UARTs are included as well.

The EP9315 is a high-performance, low-power RISC-based single-chip computer built around an ARM920T microprocessor core with a maximum operating clock rate of 200 MHz (184 MHz for industrial conditions). The ARM core operates from a 1.8 V supply, while the I/O operates at 3.3 V with power usage between 100 mW and 750 mW (dependent on speed).

Table A. Change History

Revision	Date	Changes
1	January 2004	Initial Release.
2	July 2004	Update AC data. Add ADC data.

Table of Contents

FEATURES	1
OVERVIEW	2
Processor Core - ARM920T	6
MaverickCrunch™ Math Engine	6
MaverickKey™ Unique ID	6
General Purpose Memory Interface (SDRAM, SRAM, ROM, FLASH)	6
IDE Interface	7
Ethernet Media Access Controller (MAC)	7
Serial Interfaces (SPI, I2S and AC '97)	7
Raster / LCD Interface	7
Graphics Accelerator	8
Touch Screen Interface with 12-bit Analog-to-Digital Converter (ADC)	8
64-Keypad Interface	8
Universal Asynchronous Receiver/Transmitters (UARTs)	9
Triple Port USB Host	9
Two-Wire Interface With EEPROM Support	9
Real-Time Clock with Software Trim	10
PLL and Clocking	10
Timers	10
Interrupt Controller	10
Dual LED Drivers	10
General Purpose Input/Output (GPIO)	10
Reset and Power Management	11
Hardware Debug Interface	11
Internal Boot ROM	11
12-Channel DMA Controller	11
PCMCIA Interface	11
Electrical Specifications	12
Absolute Maximum Ratings	12
Recommended Operating Conditions	12
DC Characteristics	13
Timings	14
Memory Interface	15
PCMCIA Interface	29
IDE Interface	32
Ethernet MAC Interface	46
Audio Interface	48
AC'97	52
LCD Interface	53
ADC	54
JTAG	55
352 Pin BGA Package Outline	56
352-Ball PBGA Diagram	56
352 Pin BGA Pinout (Bottom View)	57
Acronyms and Abbreviations	64
Units of Measurement	64
ORDERING INFORMATION	65

List of Figures

Figure 1. Timing Diagram Drawing Key	14
Figure 2. SDRAM Load Mode Register Cycle Timing Measurement	15
Figure 3. SDRAM Burst Read Cycle Timing Measurement	16
Figure 4. SDRAM Burst Write Cycle Timing Measurement	17
Figure 5. SDRAM Auto Refresh Cycle Timing Measurement	18
Figure 6. Static Memory Single Word Read Cycle Timing Measurement	19
Figure 7. Static Memory Single Word Write Cycle Timing Measurement	20
Figure 8. Static Memory Multiple Word Read 8 Bit Cycle Timing Measurement	21
Figure 9. Static Memory Multiple Word Write 8 bit Cycle Timing Measurement	22
Figure 10. Static Memory Multiple Word Read 16 Bit Cycle Timing Measurement	23
Figure 11. Static Memory Multiple Word Write 16 bit Cycle Timing Measurement	24
Figure 12. Static Memory Burst Read Cycle Timing Measurement	25
Figure 13. Static Memory Single Read Wait Cycle Timing Measurement	26
Figure 14. Static Memory Single Write Wait Cycle Timing Measurement	27
Figure 15. Static Memory Turnaround Cycle Timing Measurement	28
Figure 16. PCMCIA Read Cycle Timing Measurement	30
Figure 17. PCMCIA Write Cycle Timing Measurement	31
Figure 18. Register Transfer to/from Device	33
Figure 19. PIO Data Transfer to/from Device	35
Figure 20. Multiword DMA Data Transfer	36
Figure 21. Initiating an Ultra DMA data-in Burst	38
Figure 22. Sustained Ultra DMA data-in Burst	39
Figure 23. Host Pausing an Ultra DMA data-in Burst	39
Figure 24. Device Terminating an Ultra DMA data-in Burst	40
Figure 25. Host Terminating an Ultra DMA data-in Burst	41
Figure 26. Initiating an Ultra DMA data-out Burst	42
Figure 27. Sustained Ultra DMA data-out Burst	43
Figure 28. Device Pausing an Ultra DMA data-out Burst	43
Figure 29. Host Terminating an Ultra DMA data-out Burst	44
Figure 30. Device Terminating an Ultra DMA data-out Burst	45
Figure 31. Ethernet MAC Timing Measurement	47
Figure 32. SPI Single Transfer Timing Measurement	49
Figure 33. Microwire Frame Format, Single Transfer	49
Figure 34. SPI Format with SPH=1 Timing Measurement	50
Figure 35. Inter-IC Sound (I2S) Timing Measurement	51
Figure 36. AC '97 Configuration Timing Measurement	52
Figure 37. LCD Timing Measurement	53
Figure 38. ADC Transfer Function	54
Figure 39. JTAG Timing Measurement	55
Figure 40. 352 Pin PBGA Pin Diagram	56
Figure 40. 352 PIN BGA PINOUT	58

List of Tables

Table A. Change History	2
Table B. General Purpose Memory Interface Pin Assignments	6
Table C. IDE Interface Pin Assignments	7
Table D. Ethernet Media Access Controller Pin Assignments	7
Table E. Audio Interfaces Pin Assignment	7
Table F. LCD Interface Pin Assignments	8
Table G. Touch Screen Interface with 12-bit Analog-to-Digital Converter Pin Assignments ...	8
Table H. 64-Key Keypad Interface Pin Assignments	8
Table I. Universal Asynchronous Receiver/Transmitters Pin Assignments	9
Table J. Triple Port USB Host Pin Assignments	9
Table K. Two-Wire Port with EEPROM Support Pin Assignments	9
Table L. Real-Time Clock with Pin Assignments	10
Table M. PLL and Clocking Pin Assignments	10
Table N. Interrupt Controller Pin Assignment	10
Table O. Dual LED Pin Assignments	10
Table P. General Purpose Input/Output Pin Assignment	11
Table Q. Reset and Power Management Pin Assignments	11
Table R. Hardware Debug Interface	11
Table S. PCMCIA Interface	11
Table R. 352 Pin Diagram Dimensions	57
Table S. Pin Descriptions	61
Table T. Pin Multiplex Usage Information	63

Processor Core - ARM920T

The ARM920T is a Harvard architecture processor with separate 16 Kbyte instruction and data caches with an 8-word line length but a unified memory. The processor utilizes a five-stage pipeline consisting of fetch, decode, execute, memory and write stages. Key features include:

- ARM (32-bit) and Thumb (16-bit compressed) instruction sets
- 32-bit Advanced Micro-Controller Bus Architecture (AMBA)
- 16 Kbyte Instruction Cache with lockdown
- 16 Kbyte Data Cache (programmable write-through or write-back) with lockdown
- MMU for Linux[®], Microsoft[®] Windows[®] CE and other operating systems
- Translation Look Aside Buffers with 64 Data and 64 Instruction Entries
- Programmable Page Sizes of 64 Kbyte, 4 Kbyte, and 1 Kbyte
- Independent lockdown of TLB Entries

MaverickCrunch[™] Math Engine

The MaverickCrunch Engine is a mixed-mode coprocessor designed primarily to accelerate the math processing required to rapidly encode digital audio formats. It accelerates single and double precision integer and floating point operations plus an integer multiply-accumulate (MAC) instruction that is considerably faster than the ARM920T's native MAC instruction. The ARM920T coprocessor interface is utilized thereby sharing its memory interface and instruction stream. Hardware forwarding and interlock allows the ARM to handle looping and addressing while MaverickCrunch handles computation. Features include:

- IEEE-754 single and double precision floating point
- 32 / 64-bit integer
- Add / multiply / compare
- Integer MAC 32-bit input with 72-bit accumulate
- Integer Shifts
- Floating point to/from integer conversion
- Sixteen 64-bit register files
- Four 72-bit accumulators

MaverickKey[™] Unique ID

MaverickKey unique hardware programmed IDs are a solution to the growing concern over secure web content and commerce. With Internet security playing an important role in the delivery of digital media such as books or music, traditional software methods are quickly becoming unreliable. The MaverickKey unique IDs

provide OEMs with a method of utilizing specific hardware IDs such as those assigned for SDMI (Secure Digital Music Initiative) or any other authentication mechanism.

Both a specific 32-bit ID as well as a 128-bit random ID is programmed into the EP9315 through the use of laser probing technology. These IDs can then be used to match secure copyrighted content with the ID of the target device the EP9315 is powering, and then deliver the copyrighted information over a secure connection. In addition, secure transactions can benefit by also matching device IDs to server IDs. MaverickKey IDs provide a level of hardware security required for today's Internet appliances.

General Purpose Memory Interface (SDRAM, SRAM, ROM, FLASH)

The EP9315 features a unified memory address model where all memory devices are accessed over a common address/data bus. A separate internal port is dedicated to the read-only Raster/LCD refresh engine, while the rest of the memory accesses are performed via the Processor bus. The SRAM memory controller supports 8, 16 and 32-bit devices and accommodates an internal boot ROM concurrently with 32-bit SDRAM memory.

- 1-4 banks of 32-bit 66 or 100 MHz SDRAM
- One internal port dedicated to the Raster/LCD Refresh Engine (Read Only)
- One internal port dedicated to the rest of the chip via the Processor bus
- Address and data bus shared between SDRAM, SRAM, ROM, and FLASH memory
- Both NAND and NOR FLASH memory supported

Table B. General Purpose Memory Interface Pin Assignments

Pin Mnemonic	Pin Description
SDCLK	SDRAM Clock
SDCLKEN	SDRAM Clock Enable
SDCSn[3:0]	SDRAM Chip Selects 3-0
RASn	SDRAM RAS
CASn	SDRAM CAS
SDWEn	SDRAM Write Enable
CSn[7:6] and CSn[3:0]	Chip Selects 7, 6, 3, 2, 1, 0
AD[25:0]	Address Bus 25-0
DA[31:0]	Data Bus 31-0
DQMn[3:0]	SDRAM Output Enables / Data Masks
WRn	SRAM Write Strobe
RDn	SRAM Read / OE Strobe
WAITn	SRAM Wait Input

IDE Interface

The IDE Interface provides an industry-standard connection to two AT Advanced Packet Interface (ATAPI) compliant devices. The IDE port will attach to a master and a slave device. The internal DMA controller performs all data transfers using the Multiword DMA and Ultra DMA modes. The interface supports the following operating modes:

- PIO Mode 4
- Multiword DMA Mode 2
- Ultra DMA Mode 4

Table C. IDE Interface Pin Assignments

Pin Mnemonic	Pin Description
DD[15-0]	IDE Data bus
IDEDA[2-0]	IDE Device address
IDECSn[0,1]	IDE Chip Select 0 and 1
DIORn	IDE Read Strobe
DIOWn	IDE Write Strobe
DMACKn	IDE DMA acknowledge

Ethernet Media Access Controller (MAC)

The MAC subsystem is compliant with the ISO/TEC 802.3 topology for a single shared medium with several stations. Multiple MII-compliant PHYs are supported. Features include:

- Supports 1/10/100 Mbps transfer rates for home / small-business / large-business applications
- Interfaces to an off-chip PHY through industry standard Media Independent Interface (MII)

Table D. Ethernet Media Access Controller Pin Assignments

Pin Mnemonic	Pin Description
MDC	Management Data Clock
MDIO	Management Data I/O
RXCLK	Receive Clock
MIIRXD[3:0]	Receive Data
RXDVAL	Receive Data Valid
RXERR	Receive Data Error
TXCLK	Transmit Clock
MIITXD[3:0]	Transmit Data
TXEN	Transmit Enable
TXERR	Transmit Error
CRS	Carrier Sense
CLD	Collision Detect

Serial Interfaces (SPI, I²S and AC '97)

The SPI port can be configured as a master or a slave, supporting the National Semiconductor®, Motorola® and Texas Instruments® signaling protocols.

The AC'97 port supports multiple codecs for multichannel audio output with a single stereo input. Three I²S ports can be configured to support six channel 24 bit audio.

These ports are multiplexed so that I²S port 0 will take over either the AC'97 pins or the SPI pins. The second and third I²S ports' serial input and serial output pins are multiplexed with EGPIO[4,5,6,13]. The clocks supplied in the first I²S port are also used for the second and third I²S ports.

- Normal Mode: One SPI Port and one AC'97 Port
- I²S on SSP Mode: One AC'97 Port and up to three I²S Ports
- I²S on AC'97 Mode: One SPI Port and up to three I²S Ports

Table E. Audio Interfaces Pin Assignment

Pin Name	Normal Mode	I ² S on SSP Mode	I ² S on AC'97 Mode
	Pin Description	Pin Description	Pin Description
SCLK1	SPI Bit Clock	I ² S Serial Clock	SPI Bit Clock
SFRM1	SPI Frame Clock	I ² S Frame Clock	SPI Frame Clock
SSPRX1	SPI Serial Input	I ² S Serial Input	SPI Serial Input
SSPTX1	SPI Serial Output	I ² S Serial Output	SPI Serial Output
		(No I ² S Master Clock)	
ARSTn	AC'97 Reset	AC'97 Reset	I ² S Master Clock
ABITCLK	AC'97 Bit Clock	AC'97 Bit Clock	I ² S Serial Clock
ASYNC	AC'97 Frame Clock	AC'97 Frame Clock	I ² S Frame Clock
ASDI	AC'97 Serial Input	AC'97 Serial Input	I ² S Serial Input
ASDO	AC'97 Serial Output	AC'97 Serial Output	I ² S Serial Output

Raster / LCD Interface

The Raster / LCD interface provides data and interface signals for a variety of display types. It features fully programmable video interface timing for non-interlaced flat panel or dual scan displays. Resolutions up to 1280 x 1024 are supported from a unified SDRAM based frame buffer. A 16-bit PWM provides control for LCD panel contrast. LCD specific features include:

- Timing and interface signals for digital LCD and TFT displays
- Full programmability for either non-interlaced or dual-scan color and grayscale flat panel displays
- Dedicated data path to SDRAM controller for improved system performance
- Pixel depths of 4, 8, 16, or 18-bits per pixel or 256 levels of grayscale
- Hardware Cursor up to 64 x 64 pixels
- 256 x 18 Color Lookup Table
- Hardware Blinking
- 8-bit interface to low end panel

Table F. LCD Interface Pin Assignments

Pin Mnemonic	Pin Description
SPCLK	Pixel Clock
P[17:0]	Pixel Data Bus [17:0]
HSYNC / LP	Horizontal Synchronization / Line Pulse
VCSYNC / FP	Vertical or Composite Synchronization / Frame Pulse
BLANK	Composite Blank
BRIGHT	Pulse Width Modulated Brightness

Graphics Accelerator

The EP9315 contains a hardware graphics acceleration engine that improves graphic performance by handling block copy, block fill and hardware line draw operations. The Graphics Accelerator is used in the system to off-load graphics operations from the processor.

Pixel depths supported by the Graphics Accelerator are 4, 8, 16 or 24 bits per pixel. The 24 bits per pixel mode can be operated as packed (4 pixels every 3 words) or unpacked (1 pixel per word with the high byte unused.)

The block copy operations of the Graphics Accelerator are similar to a DMA (Direct Memory Access) transfer that understands pixel organization, block width, transparency, and transformation from 1bpp to higher 4, 8, 16 or 24bpp.

The line draw operations also allow for solid lines or dashed lines. The colors for line drawing can be either foreground color and background color or foreground color with the background being transparent.

Touch Screen Interface with 12-bit Analog-to-Digital Converter (ADC)

The touch screen interface performs all sampling, averaging, ADC range checking, and control for a wide variety of analog resistive touch screens. This controller

only interrupts the processor when a meaningful change occurs. The touch screen hardware may be disabled and the switch matrix and ADC controlled directly if desired. Features include:

- Support for 4, 5, 7, or 8-wire analog resistive touch screens.
- Flexibility - unused lines may be used for temperature sensing or other functions.
- Touch screen interrupt function.

Table G. Touch Screen Interface with 12-bit Analog-to-Digital Converter Pin Assignments

Pin Mnemonic	Pin Description
Xp, Xm	Touch screen ADC X Axis
Yp, Ym	Touch screen ADC Y Axis
SXp, SXm	Touch screen ADC X Axis Voltage Feedback
SYp, SYm	Touch screen ADC Y Axis Voltage Feedback

64-Keypad Interface

The keypad circuitry scans an 8 x 8 array of 64 normally open, single pole switches. Any one or two keys depressed will be de-bounced and decoded. An interrupt is generated whenever a stable set of depressed keys is detected. If the keypad is not utilized, the 16 column/row pins may be used as general purpose I/O. The Keypad interface:

- Provides scanning, debounce and decoding for a 64-key array.
- Scans an 8-row by 8-column matrix.
- May decode 2 keys at once.
- Generates an interrupt when a new stable key is determined.
- Also generates a 3-key reset interrupt.

Table H. 64-Key Keypad Interface Pin Assignments

Pin Mnemonic	Pin Description	Alternative Usage
COL[7:0]	Key Matrix Column Inputs	General Purpose I/O
ROW[7:0]	Key Matrix Row Inputs	General Purpose I/O

Universal Asynchronous Receiver/Transmitters (UARTs)

Three 16550-compatible UARTs are supplied. Two provide asynchronous HDLC (High-level Data Link Control) protocol support for full duplex transmit and receive. The HDLC receiver handles framing, address matching, CRC checking, control-octet transparency, and optionally passes the CRC to the host at the end of the packet. The HDLC transmitter handles framing, CRC generation, and control-octet transparency. The host must assemble the frame in memory before transmission. The HDLC receiver and transmitter use the UART FIFOs to buffer the data streams. A third IrDA[®] compatible UART is also supplied.

- UART1 supports modem bit rates up to 115.2 Kbps, supports HDLC and includes a 16 byte FIFO for receive and a 16 byte FIFO for transmit. Interrupts are generated on Rx, Tx and modem status change.
- UART2 contains an IrDA encoder operating at either the slow (up to 115 Kbps), medium (0.576 or 1.152 Mbps), or fast (4 Mbps) IR data rates. It also has a 16 byte FIFO for receive and a 16 byte FIFO for transmit.
- UART3 supports HDLC and includes a 16 byte FIFO for receive and a 16 byte FIFO for transmit. Interrupts are generated on Rx and Tx.

Table I. Universal Asynchronous Receiver/Transmitters Pin Assignments

Pin Mnemonic	Pin Name - Description
TXD0	UART1 Transmit
RXD0	UART1 Receive
CTS _n	UART1 Clear To Send / Transmit Enable
DSR _n / DCD _n	UART1 Data Set Ready / Data Carrier Detect
DTR _n	UART1 Data Terminal Ready
RTS _n	UART1 Ready To Send
EGPIO[0] / RI	UART1 Ring Indicator
TXD1 / SIROUT	UART2 Transmit / IrDA Output
RXD1 / SIRIN	UART2 Receive / IrDA Input
TXD2	UART3 Transmit
RXD2	UART3 Receive
EGPIO[3] / TEN _n	HDLC3 Transmit Enable

Triple Port USB Host

The USB Open Host Controller Interface (Open HCI) provides full speed serial communications ports at a baud rate of 12 Mbits/sec. Up to 127 USB devices (printer, mouse, camera, keyboard, etc.) and USB hubs can be connected to the USB host in the USB “tiered-start” topology.

This includes the following features:

- Compliance with the USB 2.0 specification
- Compliance with the Open HCI Rev 1.0 specification
- Supports both low speed (1.5 Mbps) and full speed (12 Mbps) USB device connections
- Root HUB integrated with 3 downstream USB ports
- Transceiver buffers integrated, over-current protection on ports
- Supports power management
- Operates as a master on the bus

The Open HCI host controller initializes the master DMA transfer with the AHB bus:

- Fetches endpoint descriptors and transfer descriptors
- Accesses endpoint data from system memory
- Accesses the HC communication area
- Writes status and retire transfer descriptor

Table J. Triple Port USB Host Pin Assignments

Pin Mnemonic	Pin Name - Description
USBp[2:0]	USB Positive signals
USBm[2:0]	USB Negative Signals

Two-Wire Interface With EEPROM Support

The two-wire interface provides communication and control for EEPROM devices. The EPROM Controller may download device configuration information upon chip reset.

Table K. Two-Wire Port with EEPROM Support Pin Assignments

Pin Mnemonic	Pin Name - Description	Alternative Usage
EECLK	EEPROM / Two-Wire Interface Clock	General Purpose I/O
EEDATA	EEPROM / Two-Wire Interface Data	General Purpose I/O
SLA[1:0]	External Power Switch Control	General Purpose I/O

Real-Time Clock with Software Trim

The software trim feature on the real time clock (RTC) provides software controlled digital compensation of the 32.768 KHz crystal oscillator. This compensation is accurate to ± 1.24 sec/month.

Table L. Real-Time Clock with Pin Assignments

Pin Mnemonic	Pin Name - Description
RTCXTALI	Real-Time Clock Oscillator Input
RTCXTALO	Real-Time Clock Oscillator Output

PLL and Clocking

The Processor and the Peripheral Clocks operate from a single 14.7456 MHz crystal.

The Real Time Clock operates from a 32.768 KHz crystal oscillator.

Table M. PLL and Clocking Pin Assignments

Pin Mnemonic	Pin Name - Description
XTALI	Main Oscillator Input
XTALO	Main Oscillator Output
VDD_PLL	Main Oscillator Power
GND_PLL	Main Oscillator Ground

Timers

The Watchdog Timer insures proper operation by requiring periodic attention to prevent a reset-on-time-out.

Two 16-bit timers operate as free running down-counters or as periodic timers for fixed interval interrupts and have a range of 0.03 ms to 4.27 seconds.

One 32-bit timer, plus a 6-bit prescale counter, has a range of 0.03 μ s to 73.3 hours.

One 40-bit debug timer, plus 6-bit prescale counter, has a range of 1.0 μ s to 12.7 days.

Interrupt Controller

The interrupt controller allows up to 64 interrupts to generate an Interrupt Request (IRQ) or Fast Interrupt Request (FIQ) signal to the processor core. Thirty-two hardware priority assignments are provided for assisting IRQ vectoring, and two levels are provided for FIQ vectoring. This allows time critical interrupts to be processed in the shortest time possible. Internal interrupts may be programmed as active high or active low level sensitive inputs. External interrupts may be

programmed as active high level sensitive, active low level sensitive, rising edge triggered, falling edge triggered, or combined rising/falling edge triggered.

- Supports 64 interrupts from a variety of sources (such as UARTs, GPIO, and key matrix)
- Routes interrupt sources to either the ARM920T's IRQ or FIQ (Fast IRQ) inputs
- Four dedicated off-chip interrupt lines operate as level sensitive interrupts
- Any of the 16 GPIO lines maybe configured to generate interrupts
- Software supported priority mask for all FIQs and IRQs

Table N. Interrupt Controller Pin Assignment

Pin Mnemonic	Pin Name - Description
INT[3:0]	External Interrupt 3-0

Dual LED Drivers

Two pins are assigned specifically to drive external LEDs.

Table O. Dual LED Pin Assignments

Pin Mnemonic	Pin Name - Description	Alternative Usage
GRLED	Green LED	General Purpose I/O
REDLED	Red LED	General Purpose I/O

General Purpose Input/Output (GPIO)

The 16 EGPIO pins may each be configured individually as an output, an input, or an interrupt input.

There are 23 pins that may alternatively be used as input, output, or open-drain pins, but do not support interrupts. These pins are:

- Key Matrix ROW[7:0], COL[7:0]
- Ethernet MDIO
- Both LED Outputs
- EEPROM Clock and Data
- SLA [1:0]

6 pins may alternatively be used as inputs only:

- CTS_n, DSR_n / DCD_n
- 4 Interrupt Lines

2 pins may alternatively be used as outputs only:

- RTS_n
- ARST_n

Table P. General Purpose Input/Output Pin Assignment

Pin Mnemonic	Pin Name - Description
EGPIO[15:0]	Expanded General Purpose Input / Output Pins with Interrupts

Reset and Power Management

The chip may be reset through the PRSTn pin or through the open drain common reset pin, RSTOn.

Clocks are managed on a peripheral-by-peripheral basis and may be turned off to conserve power.

The processor clock is dynamically adjustable from 0 to 200 MHz (184 MHz for industrial conditions).

Table Q. Reset and Power Management Pin Assignments

Pin Mnemonic	Pin Name - Description
PRSTn	Power On Reset
RSTOn	User Reset In/Out – Open Drain – Preserves Real Time Clock value

Hardware Debug Interface

The JTAG interface allows use of ARM's Multi-ICE or other in-circuit emulators.

Table R. Hardware Debug Interface

Pin Mnemonic	Pin Name - Description
TCK	JTAG Clock
TDI	JTAG Data In
TDO	JTAG Data Out
TMS	JTAG Test Mode Select
TRSTn	JTAG Port Reset

Internal Boot ROM

The Internal 16 Kbyte ROM allows booting from FLASH memory, SPI or UART.

12-Channel DMA Controller

The DMA module contains 12 separate DMA channels. Ten of these may be used for peripheral-to-memory or memory-to-peripheral access. Two of these are dedicated to memory-to-memory transfers. Each DMA channel is connected to the 16-bit DMA request bus.

The request bus is a collection of requests, Serial Audio and UARTs. Each DMA channel can be used independently or dedicated to any request signal. For each DMA channel, source and destination addressing can be independently programmed to increment, decrement, or stay at the same value. All DMA addresses are physical, not virtual addresses.

PCMCIA Interface

The EP9315 has a single PCMCIA port which can be used to access either 8 or 16 bit devices.

Table S. PCMCIA Interface

Pin Mnemonic	Pin Name - Description
VS1	Voltage sense
VS2	Voltage sense
MCD1	Card detect
MCD2	Card detect
MCBVD1	Voltage detection / status change
MCBVD2	Voltage detection
MCDIR	Data transceiver direction control
MCD AENn	Data bus transceiver enable
MCA DENn	Address bus transceiver enable
MCREGn	Memory card register
MCEHn	Memory card high byte select
MCELn	Memory card low byte select
IORDn	I/O card read
IOWRn	I/O card write
MCRDn	Memory card read
MCWRn	Memory card write
READY	Ready / interrupt
WP	Write protect
MCWAITn	Wait Input
MCRESETn	Card reset

Electrical Specifications

Absolute Maximum Ratings

(All grounds = 0 V, all voltages with respect to 0 V)

Parameter	Symbol	Min	Max	Unit
Power Supplies	RVDD	-	3.96	V
	CVDD	-	2.16	V
	VDD_PLL	-	2.16	V
	VDD_ADC	-	3.96	V
Total Power Dissipation (Note 1)		-	2	W
Input Current per Pin, DC (Except supply pins)		-	±10	mA
Output current per pin, DC		-	±50	mA
Digital Input voltage (Note 2)		-0.3	RVDD+0.3	V
Storage temperature		-40	+125	°C

Note: 1. Includes all power generated by AC and/or DC output loading.
 2. The power supply pins are at recommended maximum values.
 3. At ambient temperatures above 70° C, total power dissipation must be limited to less than 2.5 Watts.

WARNING: Operation beyond these limits may result in permanent damage to the device.
 Normal operation is not guaranteed at these extremes.

Recommended Operating Conditions

(All grounds = 0 V, all voltages with respect to 0 V)

Parameter	Symbol	Min	Typ	Max	Unit
Power Supplies	RVDD	3.0	3.3	3.6	V
	CVDD	1.65	1.80	1.94	V
	VDD_PLL	1.65	1.80	1.94	V
	VDD_ADC	3.0	3.3	3.6	V
Operating Ambient Temperature - Commercial	T _A	0	+25	+70	°C
Operating Ambient Temperature - Industrial	T _A	-40	+25	+85	°C
Processor Clock Speed - Commercial	FCLK	-	-	200	MHz
Processor Clock Speed - Industrial	FCLK	-	-	184	MHz
System Clock Speed - Commercial	HCLK	-	-	100	MHz
System Clock Speed - Industrial	HCLK	-	-	92	MHz

DC Characteristics

($T_A = 0$ to 70°C ; $CVDD = VDD_PLL = 1.8$; $RVDD = 3.3\text{ V}$;

All grounds = 0 V ; all voltages with respect to 0 V unless otherwise noted)

Parameter			Symbol	Min	Max	Unit
High level output voltage	$I_{out} = -4\text{ mA}$	(Note 4)	V_{oh}	$0.85 \times RVDD$	-	V
Low level output voltage	$I_{out} = 4\text{ mA}$		V_{ol}	-	$0.15 \times RVDD$	V
High level input voltage		(Note 5)	V_{ih}	$0.65 \times RVDD$	$VDD + 0.3$	V
Low level input voltage		(Note 5)	V_{il}	-0.3	$0.35 \times RVDD$	V
High level leakage current	$V_{in} = 3.3\text{ V}$	(Note 5)	I_{ih}	-	10	μA
Low level leakage current	$V_{in} = 0$	(Note 5)	I_{il}	-	-10	μA

Parameter		Min	Typ	Max	Unit
Power Supply Pins (Outputs Unloaded)					
Power Supply Current:	CVDD / VDD_PLL Total	-	200	-	mA
	RVDD	-	20	-	mA
Low-Power Mode Supply Current	CVDD / VDD_PLL Total	-	2.5	-	mA
	RVDD	-	1.0	-	mA

Note: 4. For open drain pins, high level output voltage is dependent on the external load.

5. All inputs that do not include internal pull-ups or pull-downs, must be externally driven for proper operation (See Table S on page 61). If an input is not driven, it should be tied to power or ground, depending on the particular function. If an I/O pin is not driven and programmed as an input, it should be tied to power or ground through its own resistor.

Timings

Timing Diagram Conventions

This data sheet contains one or more timing diagrams. The following key explains the components used in these diagrams. Any variations are clearly labelled when they occur. Therefore, no additional meaning should be attached unless specifically stated.

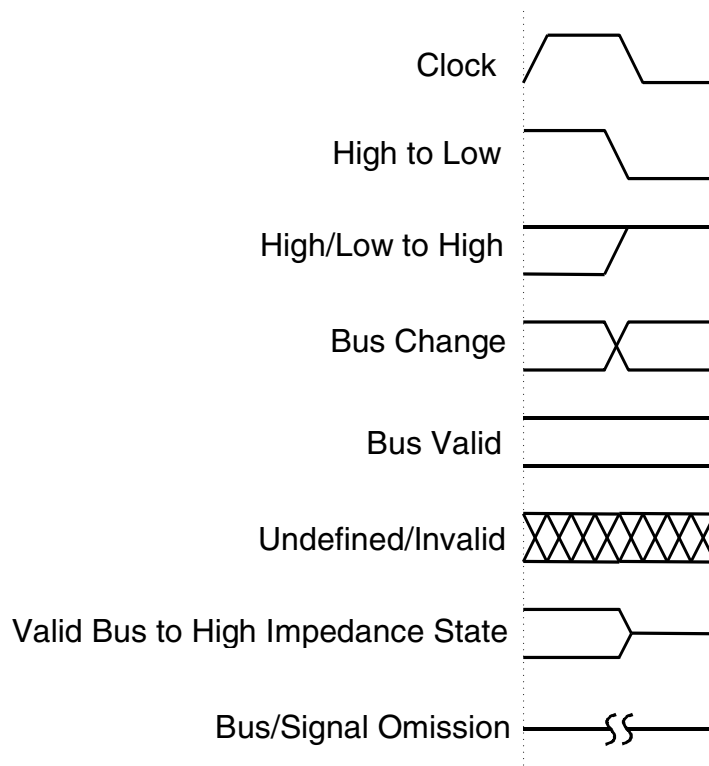

Figure 1. Timing Diagram Drawing Key

Timing Conditions

Unless specified otherwise, the following conditions are true for all timing measurements.

- $T_A = 0$ to 70°C
- $CVDD = VDD_PLL = 1.8\text{V}$
- $RVDD = 3.3\text{V}$
- All grounds = 0V
- Logic 0 = 0V , Logic 1 = 3.3V
- Output loading = 50pF
- Timing reference levels = 1.5V
- The Processor Bus Clock (HCLK) is programmable and is set by the user. The frequency is typically between 33MHz and 100MHz (92MHz for industrial conditions).

Memory Interface

Figure 2 through Figure 5 define the timings associated with all phases of the SDRAM. The following table contains the values for the timings of each of the SDRAM modes.

Parameter	Symbol	Min	Typ	Max	Unit
SDCLK high time	t_{clk_high}	-	$(t_{HCLK}) / 2$	-	ns
SDCLK low time	t_{clk_low}	-	$(t_{HCLK}) / 2$	-	ns
SDCLK rise/fall time	t_{clkrf}	-	3	-	ns
Signal delay from SDCLK rising edge time	t_d	-	8	-	ns
Signal hold from SDCLK rising edge time	t_h	-	4	-	ns
DQMn delay from SDCLK rising edge time	t_{DQd}	-	6	-	ns
DQMn hold from SDCLK rising edge time	t_{DQh}	-	6	-	ns
DA valid setup to SDCLK rising edge time	t_{DA_s}	-	2	-	ns
DA valid hold from SDCLK rising edge time	t_{DA_h}	-	2	-	ns

SDRAM Load Mode Register Cycle

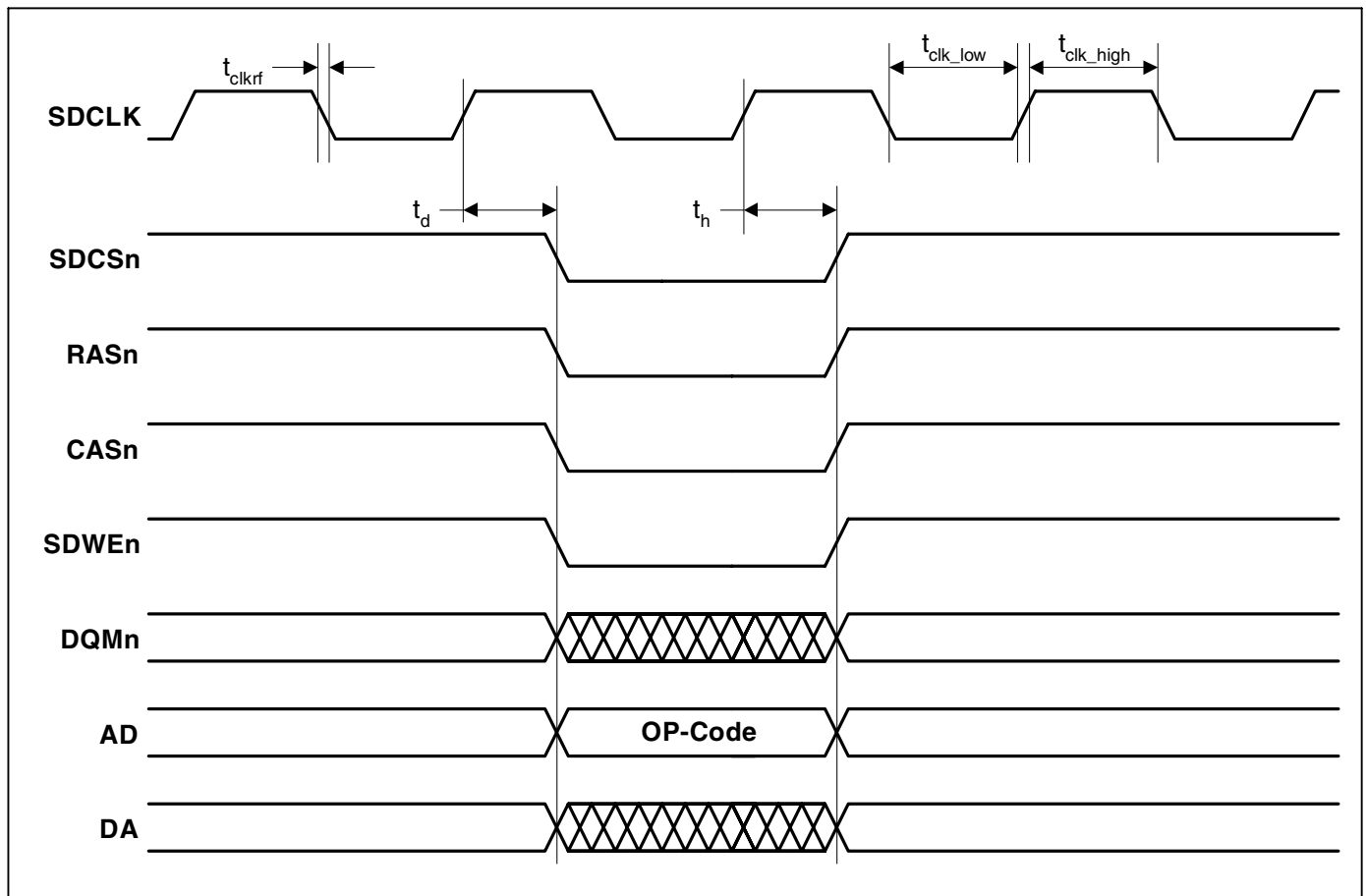

Figure 2. SDRAM Load Mode Register Cycle Timing Measurement

SDRAM Burst Read Cycle

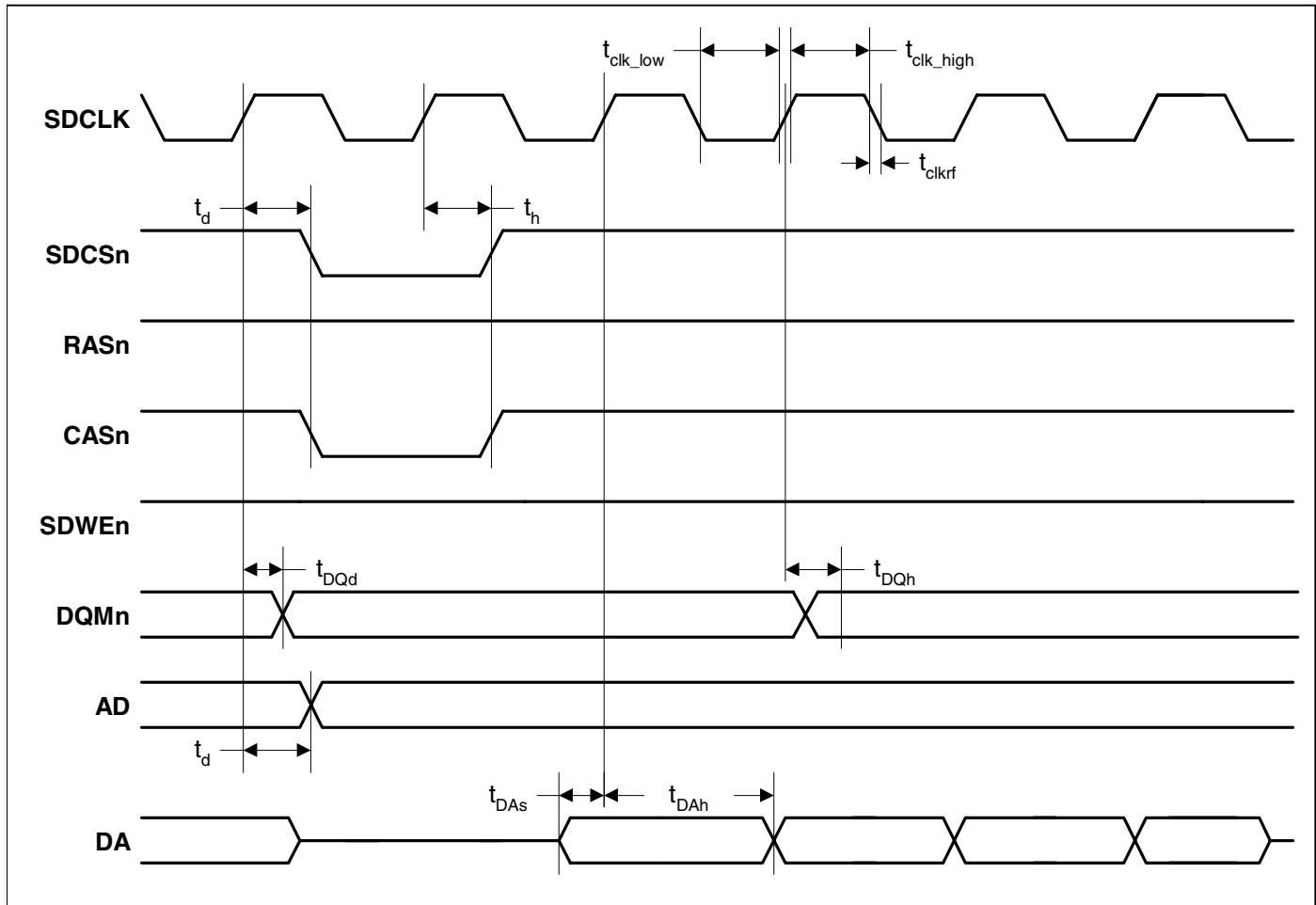

Figure 3. SDRAM Burst Read Cycle Timing Measurement

SDRAM Burst Write Cycle

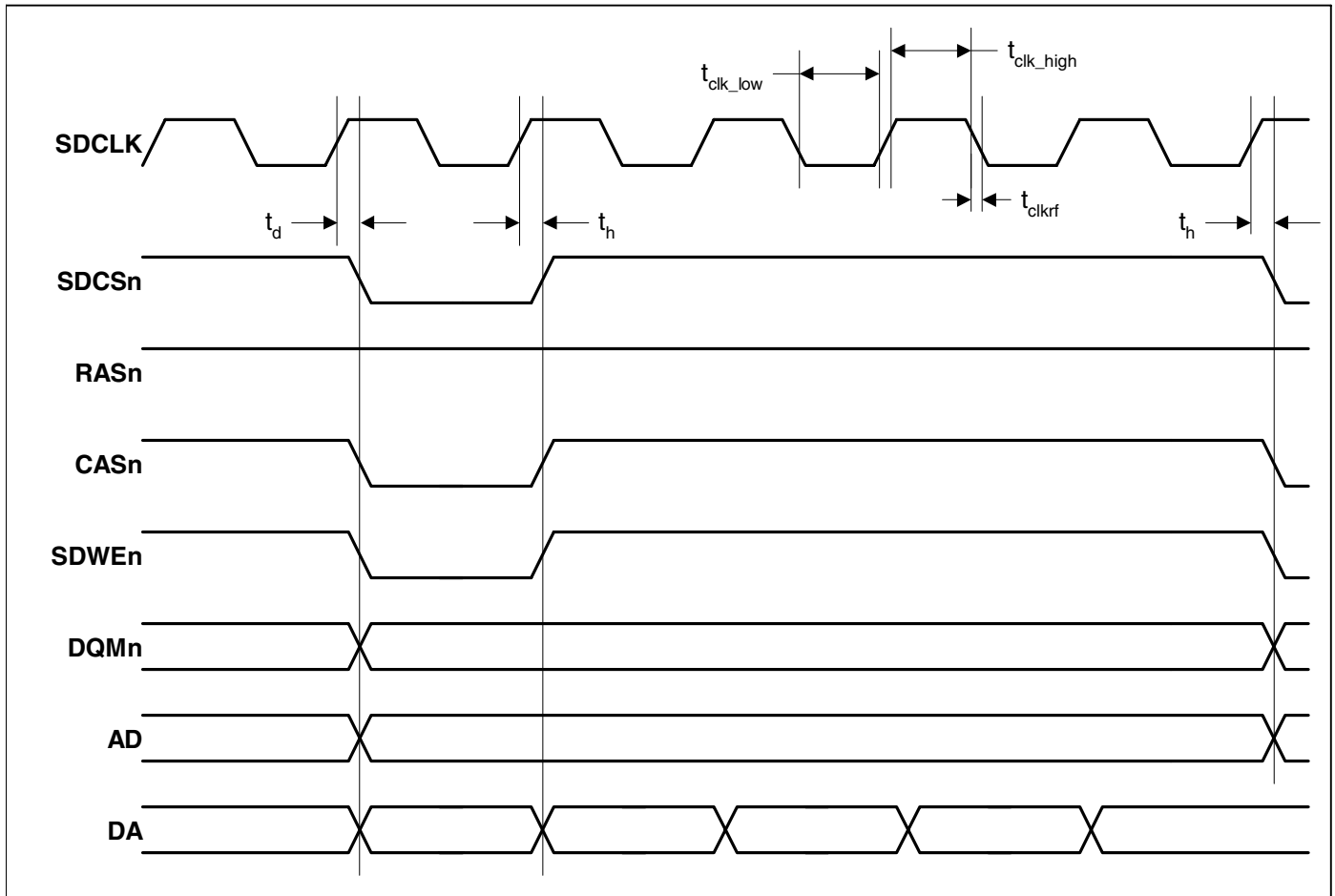
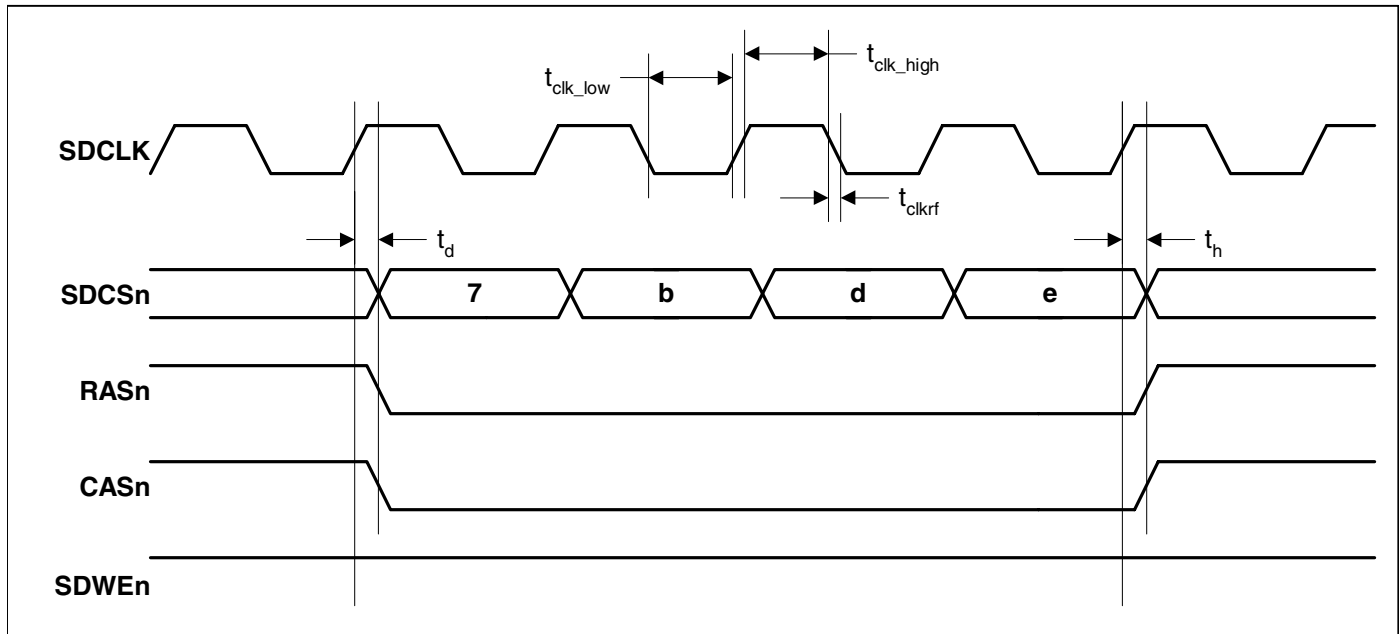

Figure 4. SDRAM Burst Write Cycle Timing Measurement

SDRAM Auto Refresh Cycle



Note: Chip select shown as bus to illustrate multiple devices being put into auto refresh in one access

Figure 5. SDRAM Auto Refresh Cycle Timing Measurement

Static Memory Single Word Read Cycle

Parameter	Symbol	Min	Typ	Max	Unit
AD setup to RDn assert time	t_{ADs}	-	5	-	ns
AD hold from RDn deassert time	t_{ADh}	-	$t_{HCLK} \times 2$	-	ns
RDn assert time	t_{RDpw}	-	$t_{HCLK} \times (WST1 + 2)$	$t_{HCLK} \times 33$	ns
CSn assert to RDn assert delay time	t_{RDd}	-	0	-	ns
CSn deassert to RDn deassert delay time	t_{RDh}	-	0	-	ns
CSn assert to DQMn assert delay time	t_{DQMd}	-	0	-	ns
CSn deassert to DQMn deassert delay time	t_{DQMh}	-	0	-	ns
DA setup to RDn deassert time	t_{DAs}	-	$t_{HCLK} + 6$	-	ns
DA hold from RDn deassert time	t_{DAh}	0	0	-	ns

See "Timing Conditions" on page 14 for definition of HCLK.

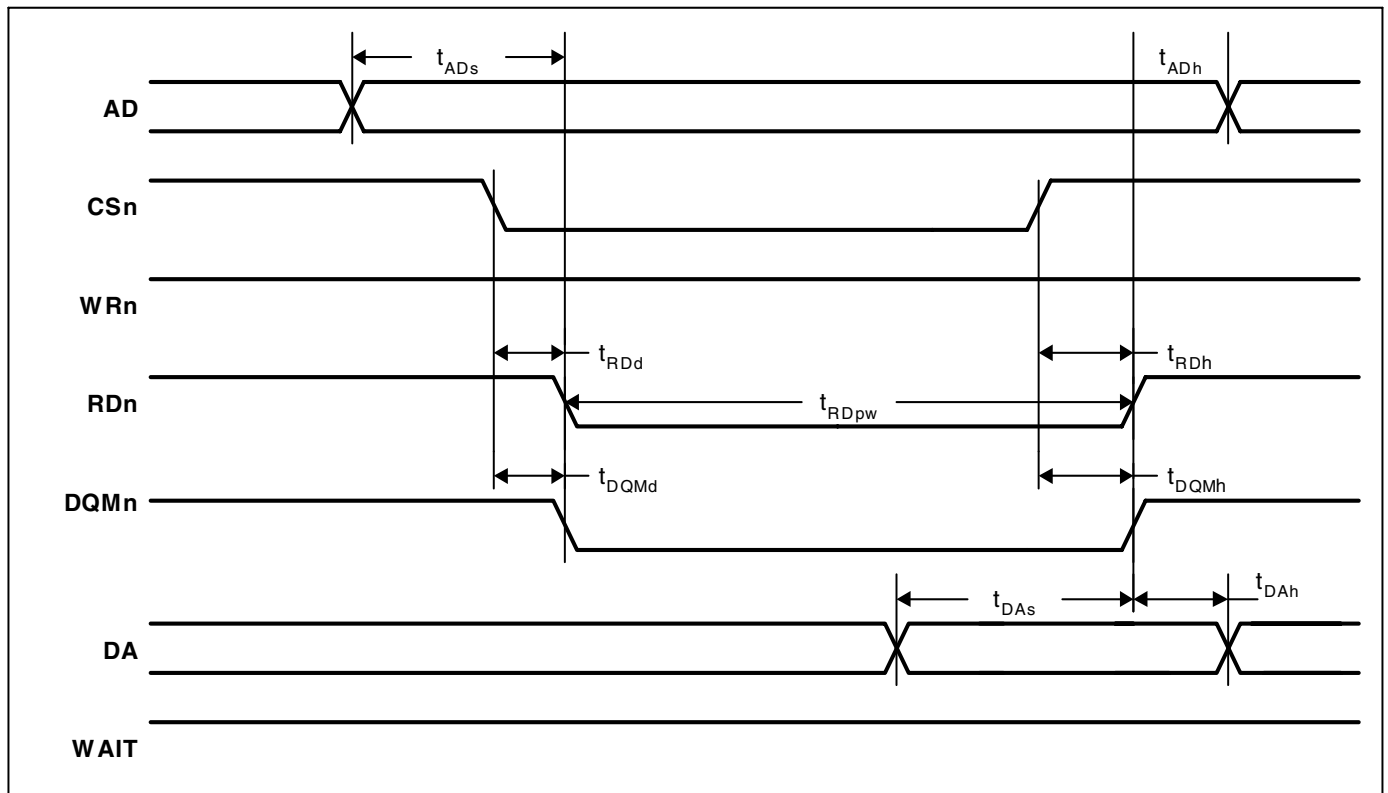

Figure 6. Static Memory Single Word Read Cycle Timing Measurement

Static Memory Single Word Write Cycle

Parameter	Symbol	Min	Typ	Max	Unit
AD setup to WRn assert time	t_{ADs}	-	t_{HCLK}	-	ns
AD hold from WRn deassert time	t_{ADh}	-	$t_{HCLK} \times 3$	-	ns
WRn deassert to CSn deassert time	t_{CSh}	-	t_{HCLK}	-	ns
CSn to WRn assert delay time	t_{WRd}	-	0	-	ns
WRn assert time	t_{WRpw}	-	$t_{HCLK} \times (WST1 + 1)$	-	ns
CSn to DQMn assert delay time	t_{DQMd}	-	0	-	ns
WRn deassert to DQMn deassert time	t_{DQMh}	-	0	-	ns
WRn deassert to DA transition time	t_{DAh}	-	t_{HCLK}	-	ns

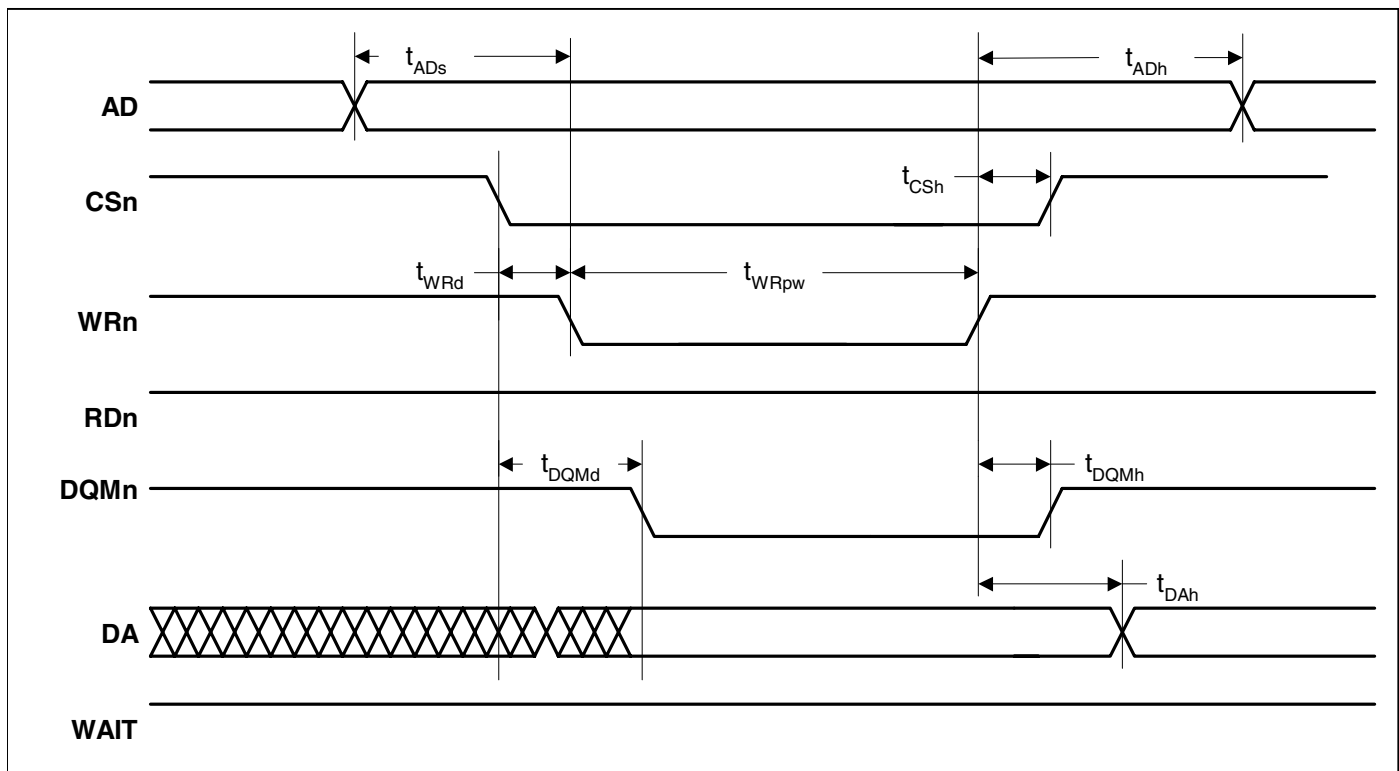
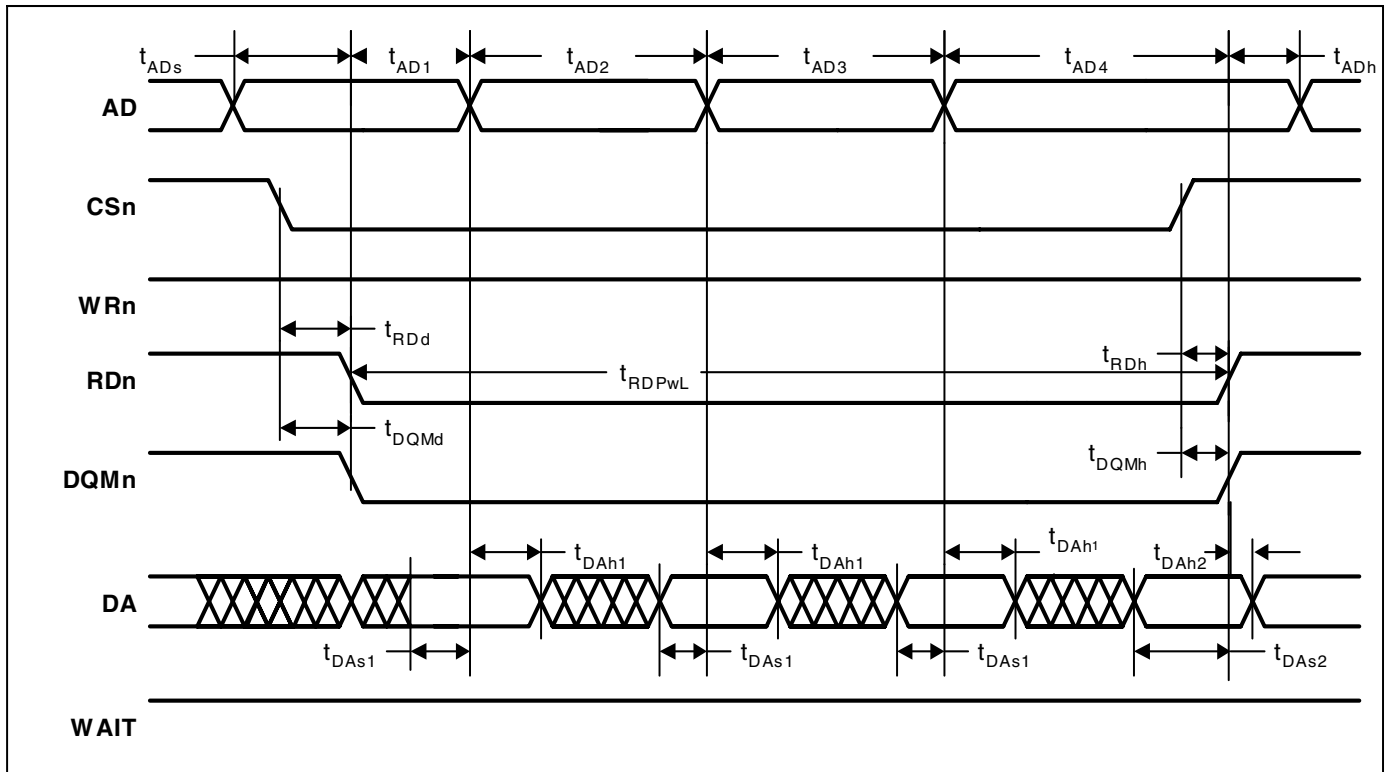

Figure 7. Static Memory Single Word Write Cycle Timing Measurement

Static Memory 32-bit Read on 8-bit External Bus

Parameter	Symbol	Min	Typ	Max	Unit
AD setup to RDn assert time	t_{ADs}	-	t_{HCLK}	-	ns
RDn assert to Address 1 transition time	t_{AD1}	-	$t_{HCLK} \times (WST1 + 1)$	-	ns
Address 2 assert time	t_{AD2}	-	$t_{HCLK} \times (WST1 + 1)$	-	ns
Address 3 assert time	t_{AD3}	-	$t_{HCLK} \times (WST1 + 1)$	-	ns
AD transition to RDn deassert time	t_{AD4}	-	$t_{HCLK} \times (WST1 + 2)$	-	ns
AD hold from RDn deassert time	t_{ADh}	-	$t_{HCLK} \times 2$	-	ns
RDn assert time	t_{RDpWL}	-	$t_{HCLK} \times (4 \times WST1 + 5)$	-	ns
CSn assert to RDn assert delay time	t_{RDd}	-	0	-	ns
CSn deassert to RDn deassert delay time	t_{RDh}	-	0	-	ns
CSn assert to DQMn assert delay time	t_{DQMd}	-	0	-	ns
CSn deassert to DQMn deassert delay time	t_{DQMh}	-	0	-	ns
DA setup to AD transition time	t_{DAs1}	-	6	-	ns
DA to RDn setup time	t_{DAs2}	-	$t_{HCLK} + 6$	-	ns
AD transition to DA transition hold time	t_{DAh1}	-	0	-	ns
RDn deassert to DA transition hold time	t_{DAh2}	-	0	-	ns

Figure 8. Static Memory Multiple Word Read 8 Bit Cycle Timing Measurement

Static Memory 32-bit Write on 8-bit External Bus

Parameter	Symbol	Min	Typ	Max	Unit
AD setup to WRn assert time	t_{ADs}	-	t_{HCLK}	-	ns
WRn deassert to AD transition time	t_{ADd}	-	t_{HCLK}	-	ns
AD hold from WRn deassert time	t_{ADh}	-	$t_{HCLK} \times 3$	-	ns
CSn hold from WRn deassert time	t_{CSh}	-	t_{HCLK}	-	ns
CSn to WRn assert delay time	t_{WRd}	-	0	-	ns
WRn assert time	t_{WRpwL}	-	$t_{HCLK} \times (WST1 + 1)$	-	ns
WRn deassert time	t_{WRpwH}	-	$t_{HCLK} \times 2$	-	ns
CSn to DQMn assert delay time	t_{DQMd}	-	0	-	ns
DQMn assert time	t_{DQMpwL}	-	$t_{HCLK} \times (WST1 + 1)$	-	ns
DQMn deassert time	t_{DQMpwH}	-	$t_{HCLK} \times 2$	-	ns
WRn / DQMn deassert to DA transition time	t_{DAh}	-	t_{HCLK}	-	ns

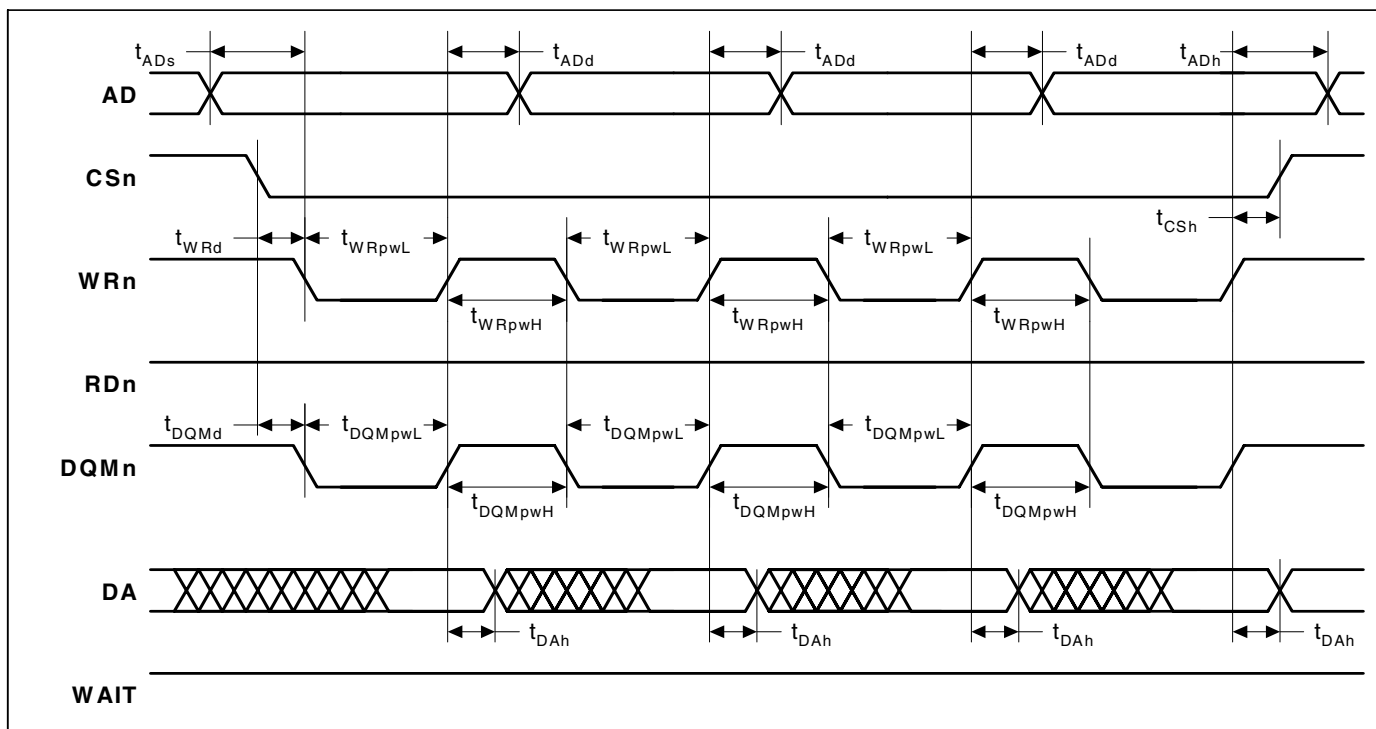
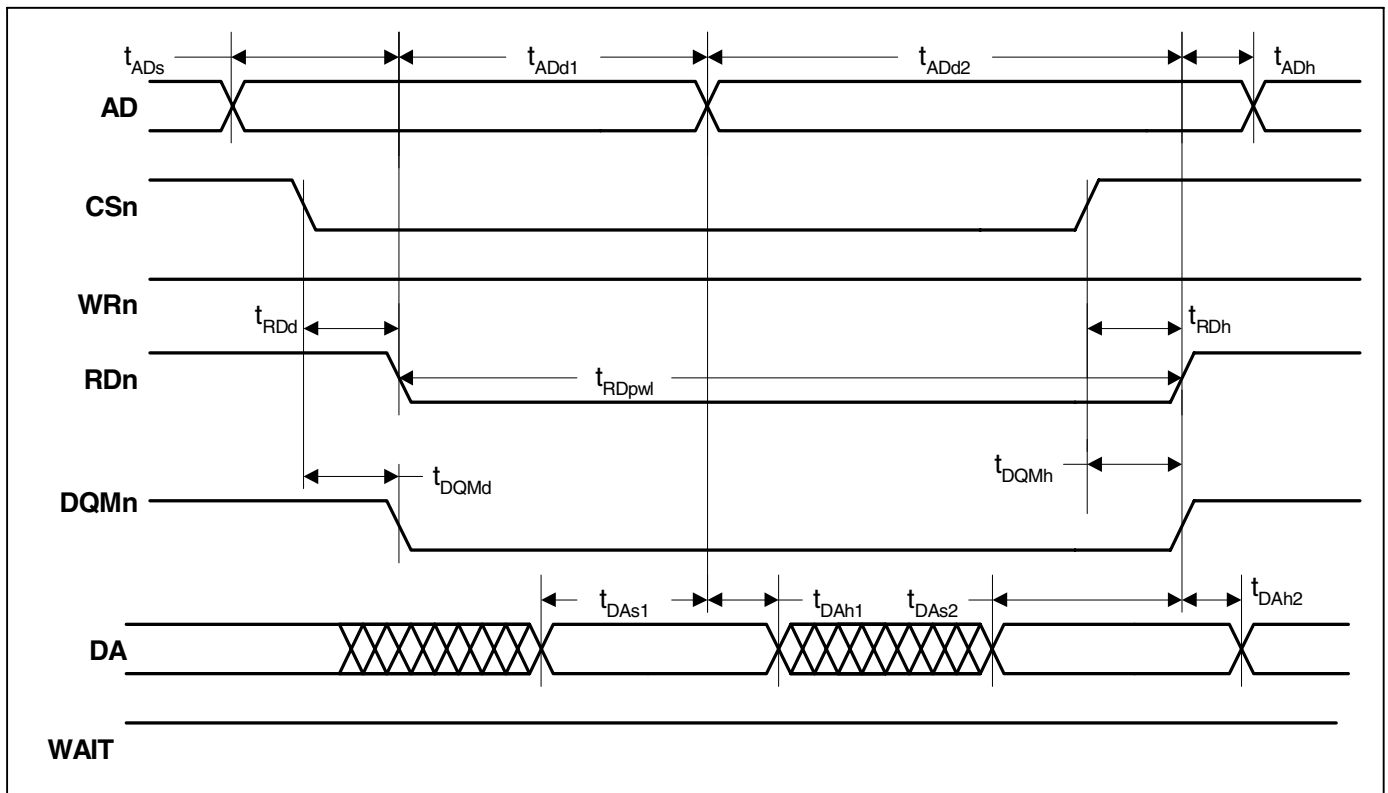

Figure 9. Static Memory Multiple Word Write 8 bit Cycle Timing Measurement

Static Memory 32-bit Read on 16-bit External Bus

Parameter	Symbol	Min	Typ	Max	Unit
AD setup to RDn assert time	t_{ADs}	-	t_{HCLK}	-	ns
RDn assert to AD transition time	t_{ADd1}	-	$t_{HCLK} \times (WST1 + 1)$	-	ns
AD transition to RDn deassert time	t_{ADd2}	-	$t_{HCLK} \times (WST1 + 2)$	-	ns
AD hold from RDn deassert time	t_{ADh}	-	$t_{HCLK} \times 2$	-	ns
RDn assert time	t_{RDpwL}	-	$t_{HCLK} \times (2 \times WST1 + 3)$	-	ns
CSn to RDn assert delay time	t_{RDd}	-	0	-	ns
CSn to RDn deassert delay time	t_{RDh}	-	0	-	ns
CSn to DQMn assert delay time	t_{DQMd}	-	0	-	ns
CSn to DQMn deassert delay time	t_{DQMh}	-	0	-	ns
DA to ADsetup time	t_{DAs1}	-	6	-	ns
DA to RDn setup time	t_{DAs2}	-	$t_{HCLK} + 6$	-	ns
AD transition to DA transition hold time	t_{DAh1}	-	0	-	ns
RDn deassert to DA transition hold time	t_{DAh2}	-	0	-	ns

Figure 10. Static Memory Multiple Word Read 16 Bit Cycle Timing Measurement

Static Memory 32-bit Write on 16-bit External Bus

Parameter	Symbol	Min	Typ	Max	Unit
AD setup to WRn assert time	t_{ADs}	-	t_{HCLK}	-	ns
WRn deassert to AD transition time	t_{ADd}	-	t_{HCLK}	-	ns
AD hold from WRn deassert time	t_{ADh}	-	$2 \times t_{HCLK}$	-	ns
CSn hold from WRn deassert time	t_{CSH}	-	t_{HCLK}	-	ns
CSn to WRn assert delay time	t_{WRd}	-	0	-	ns
WRn assert time	t_{WRpwL}	-	$t_{HCLK} \times (WST1 + 1)$	-	ns
WRn deassert time	t_{WRpwH}	-	$t_{HCLK} \times 2$	-	ns
CSn to DQMn assert delay time	t_{DQMd}	-	0	-	ns
DQMn assert time	t_{DQmpwL}	-	$t_{HCLK} \times (WST1 + 1)$	-	ns
DQMn deassert time	t_{DQmpwH}	-	$t_{HCLK} \times 2$	-	ns
WRn / DQMn deassert to DA transition time	t_{DAh1}	-	t_{HCLK}	-	ns
WRn / DQMn deassert to DA transition time	t_{DAh2}	-	t_{HCLK}	-	ns

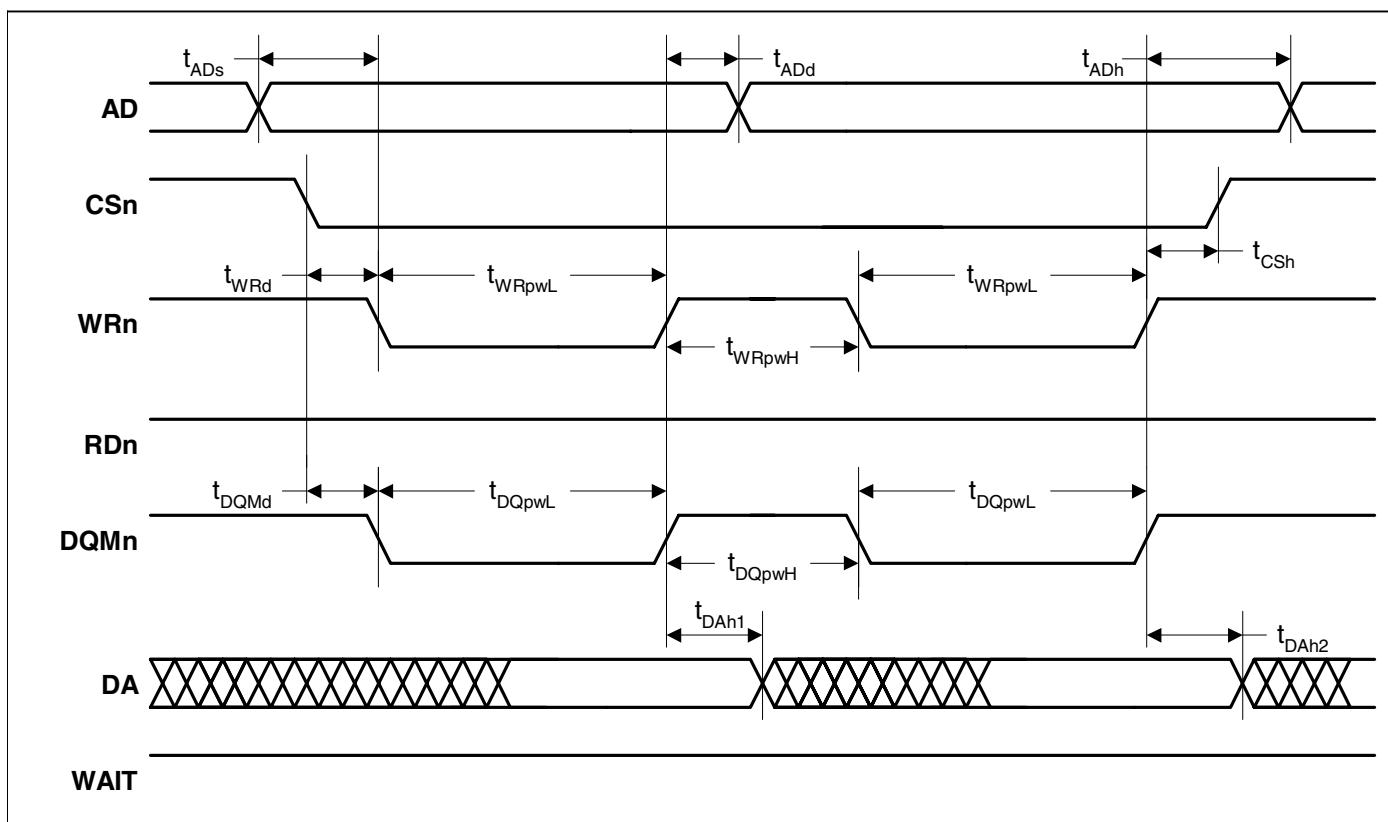

Figure 11. Static Memory Multiple Word Write 16 bit Cycle Timing Measurement

Static Memory Burst Read Cycle

Parameter	Symbol	Min	Typ	Max	Unit
CSn assert to Address 1 transition time	t_{ADd1}	-	$t_{HCLK} \times (WST1 + 1)$	-	ns
Address 2 assert time	t_{ADd2}	-	$t_{HCLK} \times (WST2 + 1)$	-	ns
AD hold from CSn deassert time	t_{ADh}	-	$t_{HCLK} \times 2$	-	ns
CSn assert time	t_{CSpw}	-	$t_{HCLK} \times ((WST1 + 1) + 4(WST2 + 1))$	-	ns
CSn to RDn assert delay time	t_{RDd}	-	0	-	ns
RDn assert time	t_{RDpw}	-	$t_{HCLK} \times ((WST1 + 1) + 4(WST2 + 1))$	-	ns
CSn to DQMn assert delay time	t_{DQMd}	-	4	-	ns
DQMn assert time	t_{DQMpw}	-	$t_{HCLK} \times ((WST1 + 1) + 4(WST2 + 1))$	-	ns
DA to AD setup time	t_{DAs1}	-	6	-	ns
DA to CSn setup time	t_{DAs2}	-	$t_{HCLK} + 6$	-	ns
AD transition to DA transition hold time	t_{DAh1}	-	0	-	ns
CSn deassert to DA transition hold time	t_{DAh2}	0	0	-	ns

Note: These characteristics are valid when the Page Mode Enable (Burst Mode) bit is set. See the User's Guide for details.

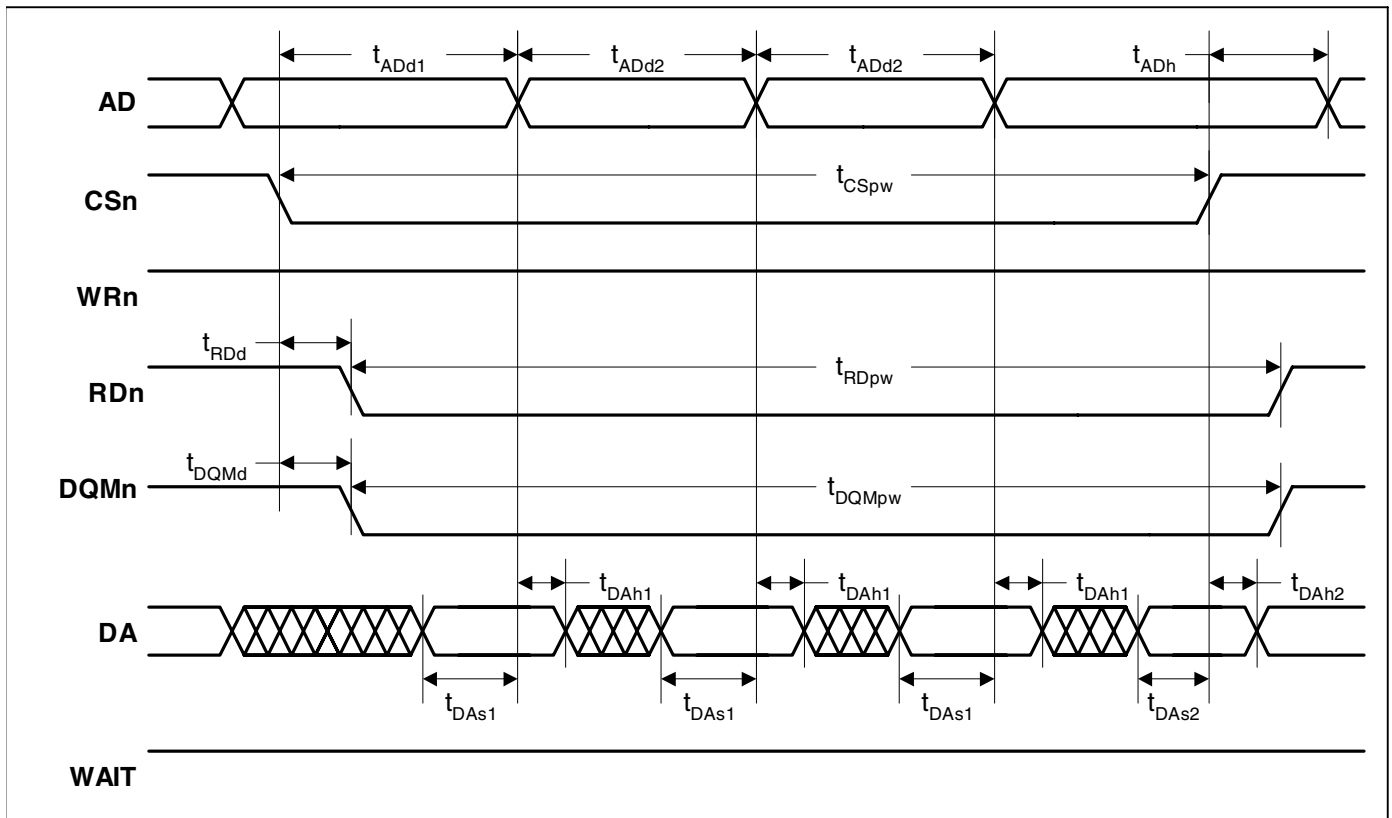

Figure 12. Static Memory Burst Read Cycle Timing Measurement

Static Memory Single Read Wait Cycle

Parameter	Symbol	Min	Typ	Max	Unit
CSn assert to WAIT time	t_{WAITd}	-	-	$t_{HCLK} \times (WST1-2)$	ns
WAIT assert time	t_{WAITpw}	$t_{HCLK} \times 2$	-	$t_{HCLK} \times 510$	ns
WAIT to CSn deassert delay time	t_{CSnd}	$t_{HCLK} \times 3$	-	$t_{HCLK} \times 5$	ns

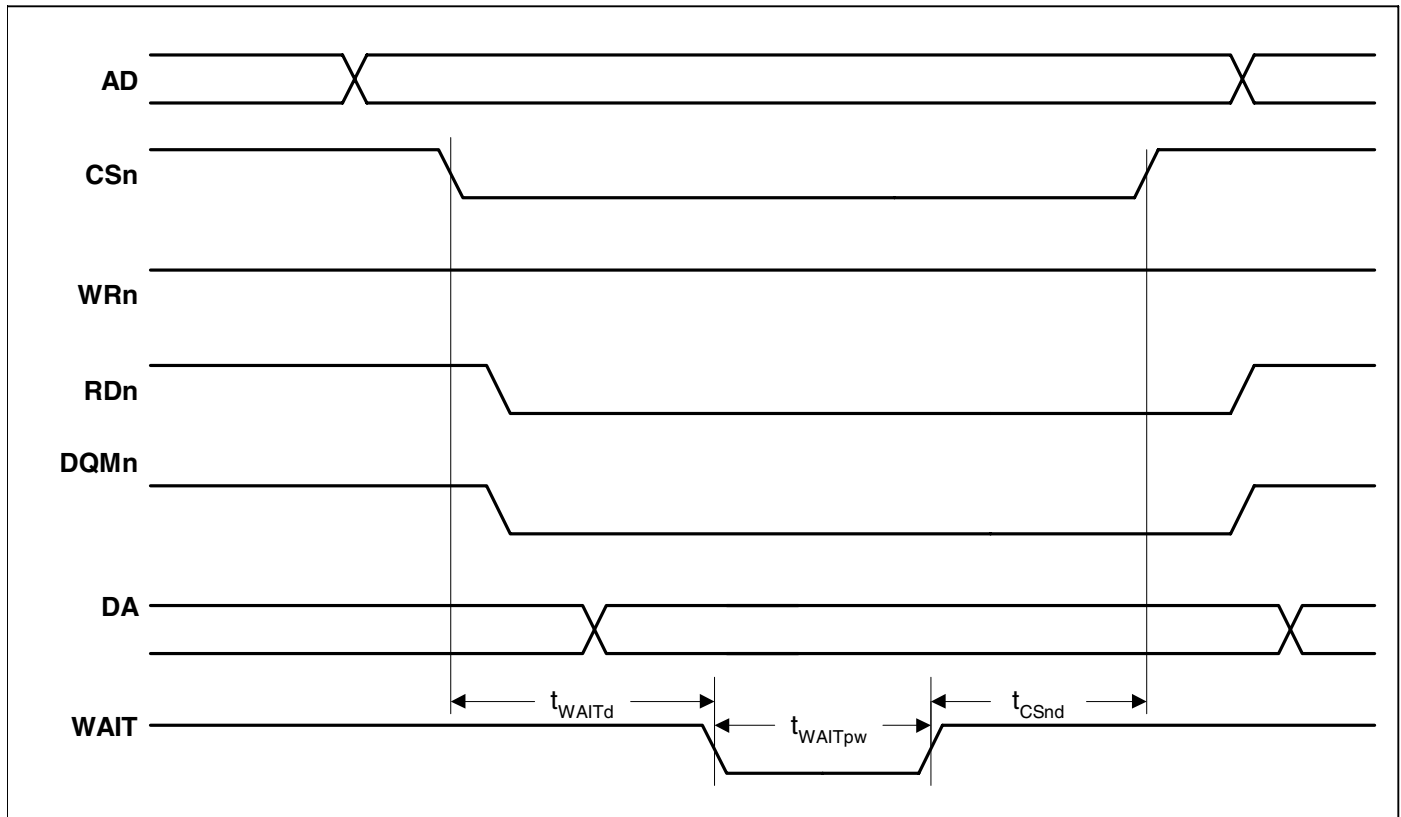
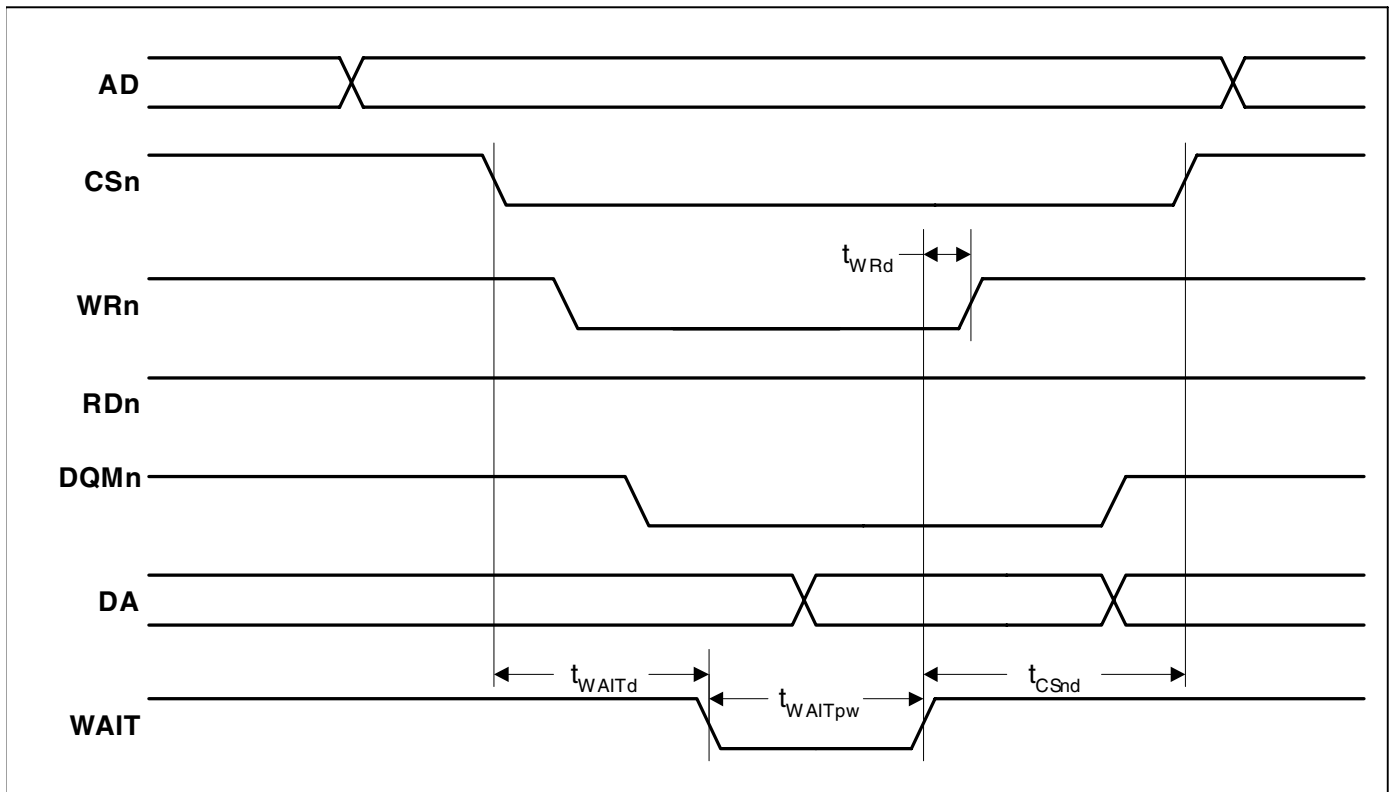

Figure 13. Static Memory Single Read Wait Cycle Timing Measurement

Static Memory Single Write Wait Cycle

Parameter	Symbol	Min	Typ	Max	Unit
WAIT to WRn deassert delay time	t_{WRd}	$t_{HCLK} \times 2$	-	$t_{HCLK} \times 4$	ns
CSn assert to WAIT time	t_{WAITd}	-	-	$t_{HCLK} \times (WST1-2)$	ns
WAIT assert time	t_{WAITpw}	$t_{HCLK} \times 2$	-	$t_{HCLK} \times 510$	ns
WAIT to CSn deassert delay time	t_{CSnd}	$t_{HCLK} \times 3$	-	$t_{HCLK} \times 5$	ns

Figure 14. Static Memory Single Write Wait Cycle Timing Measurement

Static Memory Turnaround Cycle

Parameter	Symbol	Min	Typ	Max	Unit
CSnX deassert to CSnY assert time	t_{BTcyc}	-	$t_{HCLK} \times (IDCY+1)$	-	ns

Note: X and Y represent any two chip select numbers.

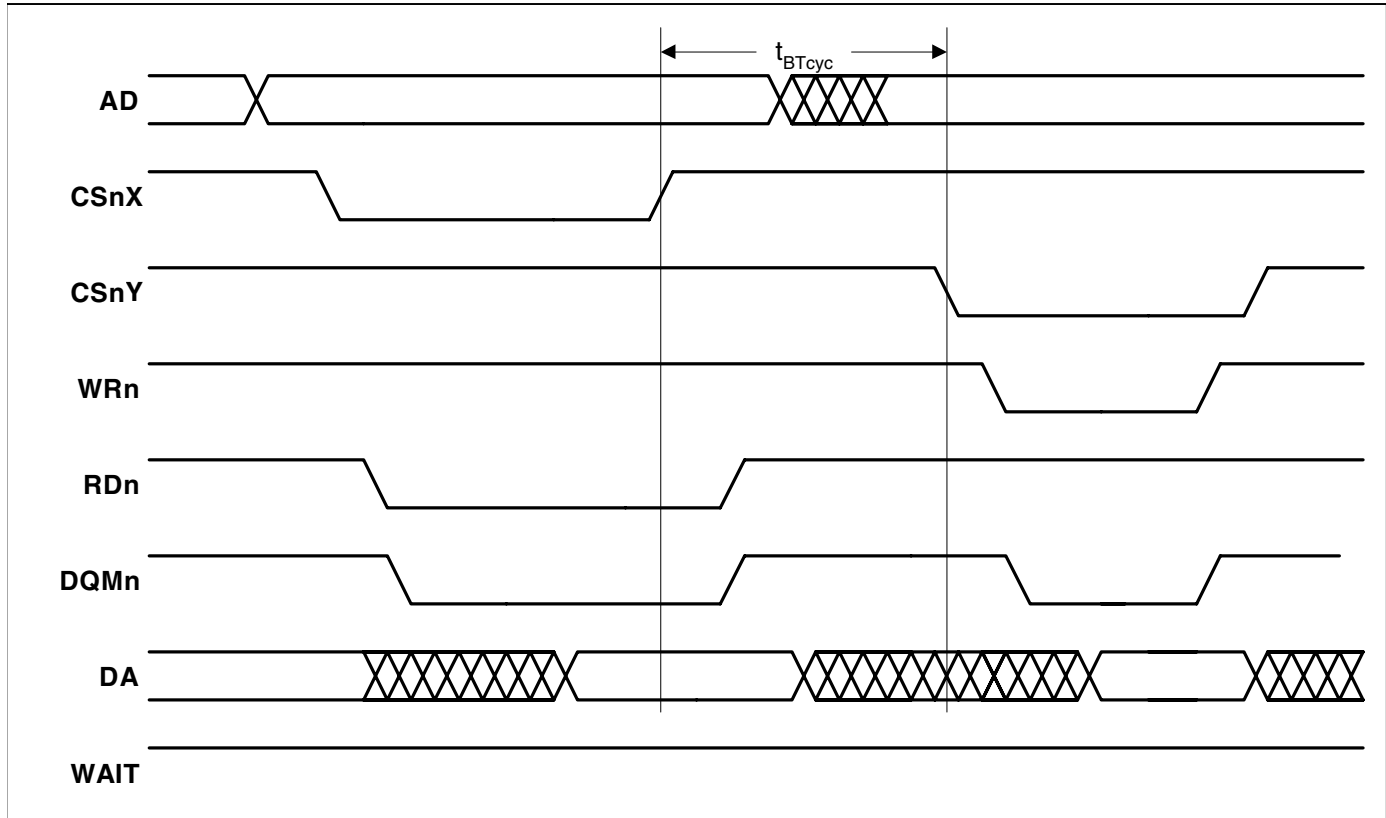

Figure 15. Static Memory Turnaround Cycle Timing Measurement

PCMCIA Interface

PCMCIA Read Cycle

Parameter	Symbol	Min	Typ	Max	Unit
MCADENn / MCDAENn delay time	$t_{MCA\text{d}}$	-	2	-	ns
MCADENn / MCDAENn hold time	$t_{MCA\text{h}}$	-	2	-	ns
MCEHn / MCELn / MCREGn signal valid delay time	$t_{MCE\text{d}}$	-	0	-	ns
MCEHn / MCELn / MCREGn hold time	$t_{MCE\text{h}}$	-	0	-	ns
Attribute access time	t_A	-	$(AA + 1) \times t_{\text{HCLK}}$	-	ns
Attribute hold time	t_H	-	$(HA + 1) \times t_{\text{HCLK}}$	-	ns
Attribute space pre-charge delay time	t_p	-	$(PA + 1) \times t_{\text{HCLK}}$	-	ns
Common access time	t_A	-	$(AC + 1) \times t_{\text{HCLK}}$	-	ns
Common hold time	t_H	-	$(HC + 1) \times t_{\text{HCLK}}$	-	ns
Common space pre-charge delay time	t_p	-	$(PC + 1) \times t_{\text{HCLK}}$	-	ns
I/O access time	t_A	-	$(AI + 1) \times t_{\text{HCLK}}$	-	ns
I/O hold time	t_H	-	$(HI + 1) \times t_{\text{HCLK}}$	-	ns
I/O space pre-charge delay time	t_p	-	$(PI + 1) \times t_{\text{HCLK}}$	-	ns
MCDIR signal valid delay time	$t_{MCD\text{d}}$	-	2	-	ns
MCDIR hold time	$t_{MCD\text{h}}$	0	-	-	ns
DA setup to MCRDn / IORDn rising edge	t_s	-	5	-	ns
DA hold from MCRDn / IORDn rising edge	t_h	-	0	-	ns

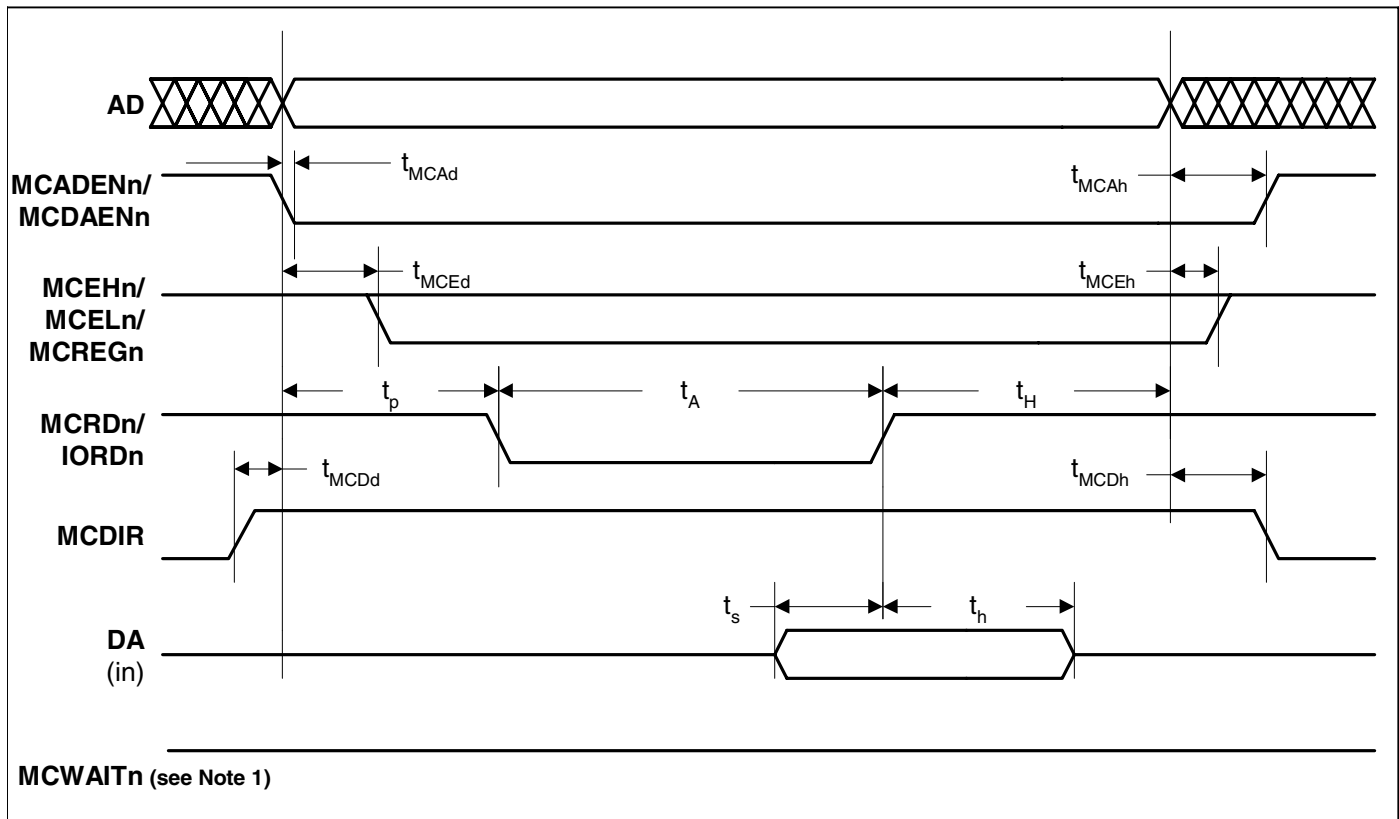
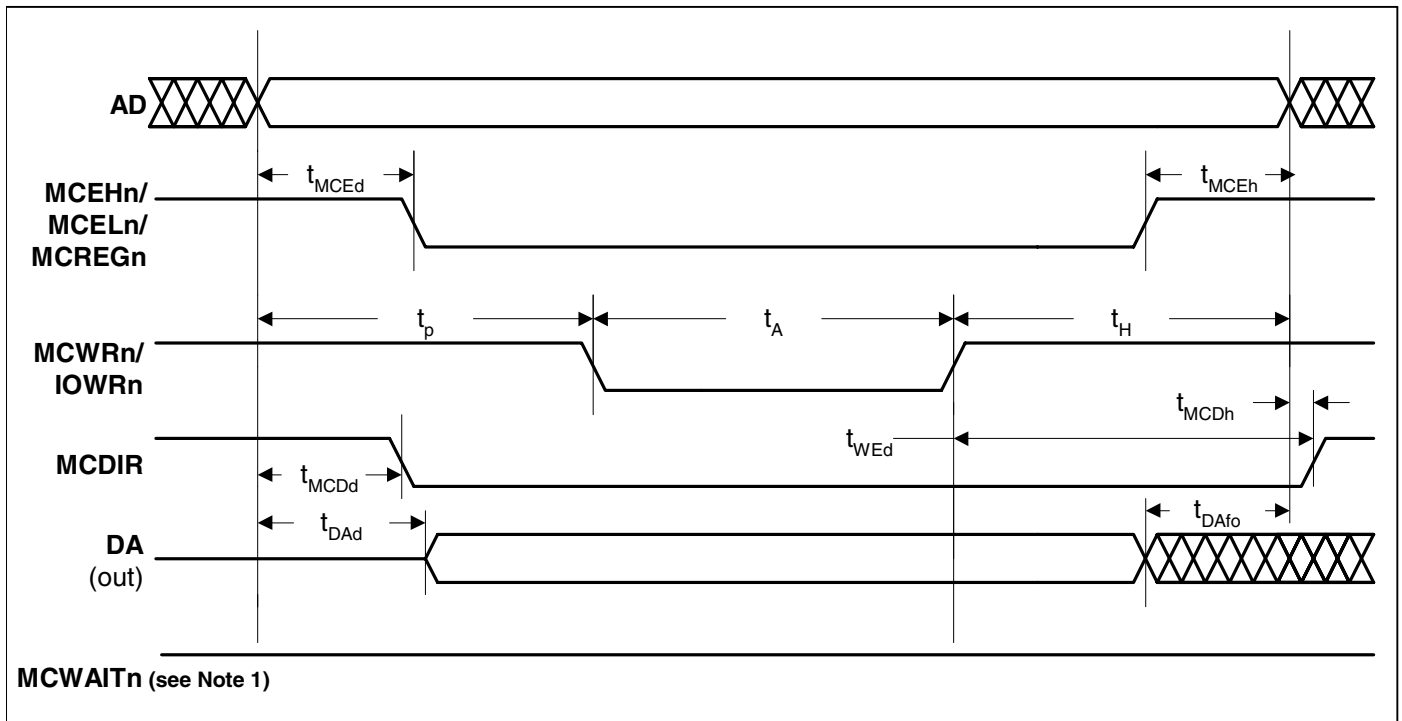

Figure 16. PCMCIA Read Cycle Timing Measurement

Note: 1 - MCWAITn asserted will extend the MCWR / IOWR strobe time.

PCMCIA Write Cycle

Parameter	Symbol	Min	Typ	Max	Unit
MCADR transition to signal transition time	t_{MCEd}	-	0	-	ns
Signal hold time	t_{MCEh}	-	0	-	ns
Attribute access time	t_A	-	$(AA + 1) \times t_{HCLK}$	-	ns
Attribute hold time	t_H	-	$(HA + 1) \times t_{HCLK}$	-	ns
Attribute space pre-charge delay time	t_p	-	$(PA + 1) \times t_{HCLK}$	-	ns
Common access time	t_A	-	$(AC + 1) \times t_{HCLK}$	-	ns
Common hold time	t_H	-	$(HC + 1) \times t_{HCLK}$	-	ns
Common space pre-charge delay time	t_p	-	$(PC + 1) \times t_{HCLK}$	-	ns
I/O access time	t_A	-	$(AI + 1) \times t_{HCLK}$	-	ns
I/O hold time	t_H	-	$(HI + 1) \times t_{HCLK}$	-	ns
I/O space pre-charge delay time	t_p	-	$(PI + 1) \times t_{HCLK}$	-	ns
MCADR transition to MCDIR transition time	t_{MCDd}	-	2	-	ns
MCDIR hold time	t_{MCDfo}	0	-	-	ns
DATA valid delay time	t_{DAd}	-	1	-	ns
DATA invalid delay time	t_{DAfo}	-	0	-	ns
MCWRn / IOWRn deassert to MCDIR deassert time	t_{WEd}	0	-	-	ns

Figure 17. PCMCIA Write Cycle Timing Measurement

Note: 1 - MCWAITn asserted will extend the MCWR / IOWR strobe time.

IDE Interface

Register Transfers

Parameter	Symbol	Mode 0 (in ns)	Mode 1 (in ns)	Mode 2 (in ns)	Mode 3 (in ns)	Mode 4 (in ns)
Cycle time (min) (Notes 1,4)	t_0	600	383	330	180	120
Address valid to DIORn / DIOwn setup (min)	t_1	70	50	30	30	25
DIORn / DIOwn pulse width 8-bit (min) (Note 1)	t_2	290	290	290	80	70
DIORn / DIOwn recovery time (min) (Note 1)	t_{2i}	-	-	-	70	25
DIOwn data setup (min)	t_3	60	45	30	30	20
DIOwn data hold (min)	t_4	30	20	15	10	10
DIORn data setup (min)	t_5	50	35	20	20	20
DIORn data hold (min)	t_6	5	5	5	5	5
DIORn data high impedance state (max) (Note 2)	t_{6z}	30	30	30	30	30
DIORn / DIOwn to address valid hold (min)	t_9	20	15	10	10	10
Read Data Valid to IORDY active (if IORDY initially low after t_A) (min)	t_{RD}	0	0	0	0	0
IORDY Setup time (Note 3)	t_A	35	35	35	35	35
IORDY Pulse Width (max)	t_B	1250	1250	1250	1250	1250
IORDY assertion to release (max)	t_C	5	5	5	5	5

- Note: 1. t_0 is the minimum total cycle time, t_2 is the minimum DIORn / DIOwn assertion time, and t_{2i} is the minimum DIORn / DIOwn negation time. A host implementation shall lengthen t_2 and/or t_{2i} to ensure that t_0 is equal to or greater than the value reported in the devices IDENTIFY DEVICE data. A device implementation shall support any legal host implementation.
2. This parameter specifies the time from the negation edge of DIORn to the time that the data bus is released by the device.
3. The delay from the activation of DIORn or DIOwn until the state of IORDY is first sampled. If IORDY is inactive then the host shall wait until IORDY is active before the register transfer cycle is completed. If the device is not driving IORDY negated at the t_A after the activation of DIORn or DIOwn, then t_5 shall be met and t_{RD} is not applicable. If the device is driving IORDY negated at the time t_A after the activation of DIORn or DIOwn, then t_{RD} shall be met and t_5 is not applicable.
4. ATA / ATAPI standards prior to ATA / ATAPI-5 inadvertently specified an incorrect value for mode 2 time t_0 by utilizing the 16-bit PIO value.

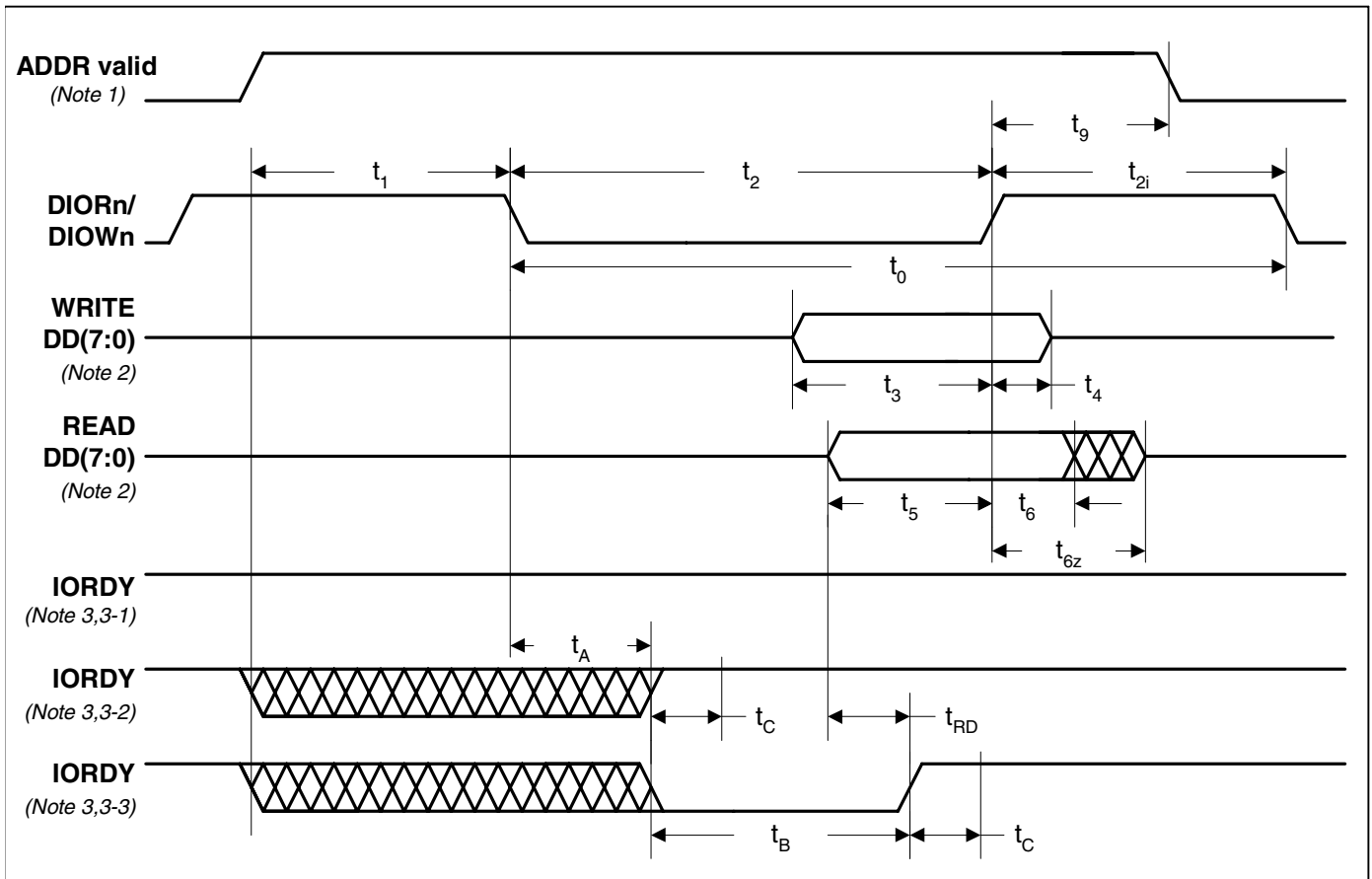

- Note:
1. Device address consists of signals CS0n, CS1n and DA (2:0)
 2. Data consists of DD (7:0)
 3. The negation of IORDY by the device is used to extend the register transfer cycle. The determination of whether the cycle is to be extended is made by the host after t_A from the assertion of DIORn or DIOWn. The assertion and negation of IORDY are described in the following three cases:
 - 3-1 Device never negates IORDY, devices keeps IORDY released: no wait is generated.
 - 3-2 Device negates IORDY before t_A , but causes IORDY to be asserted before t_A . IORDY is released prior to negation and may be asserted for no more than 5 ns before release: no wait generated.
 - 3-3 Device negates IORDY before t_A . IORDY is released prior to negation and may be asserted for no more than 5 ns before release: wait generated. The cycle completes after IORDY is reasserted. For cycles where a wait is generated and DIORn is asserted, the device shall place read data on DD (7:0) for t_{RD} before asserting IORDY.

Figure 18. Register Transfer to/from Device

PIO Data Transfers

Parameter	Symbol	Mode 0 (in ns)	Mode 1 (in ns)	Mode 2 (in ns)	Mode 3 (in ns)	Mode 4 (in ns)
Cycle time (min) (Note 1)	t_0	600	383	240	180	120
Address valid to DIORn / DIOWn setup (min)	t_1	70	50	30	30	25
DIORn / DIOWn 16-bit (min) (Note 1)	t_2	165	125	100	80	70
DIORn / DIOWn recovery time (min) (Note 1)	t_{2i}	-	-	-	70	25
DIOWn data setup (min)	t_3	60	45	30	30	20
DIOWn data hold (min)	t_4	30	20	15	10	10
DIORn data setup (min)	t_5	50	35	20	20	20
DIORn data hold (min)	t_6	5	5	5	5	5
DIORn data high impedance state (max) (Note 2)	t_{6z}	30	30	30	30	30
DIORn / DIOWn to address valid hold (min)	t_9	20	15	10	10	10
Read Data Valid to IORDY active (if IORDY initially low after t_A) (min)	t_{RD}	0	0	0	0	0
IORDY Setup time (Note 3)	t_A	35	35	35	35	35
IORDY Pulse Width (max)	t_B	1250	1250	1250	1250	1250
IORDY assertion to release (max)	t_C	5	5	5	5	5

- Note: 1. t_0 is the minimum total cycle time, t_2 is the minimum DIORn / DIOWn assertion time, and t_{2i} is the minimum DIORn / DIOWn negation time. A host implementation shall lengthen t_2 and/or t_{2i} to ensure that t_0 is equal to or greater than the value reported in the devices IDENTIFY DEVICE data. A device implementation shall support any legal host implementation.
2. This parameter specifies the time from the negation edge of DIORn to the time that the data bus is released by the device.
3. The delay from the activation of DIORn or DIOWn until the state of IORDY is first sampled. If IORDY is inactive then the host shall wait until IORDY is active before the register transfer cycle is completed. If the device is not driving IORDY negated at the t_A after the activation of DIORn or DIOWn, then t_5 shall be met and t_{RD} is not applicable. If the device is driving IORDY negated at the time t_A after the activation of DIORn or DIOWn, then t_{RD} shall be met and t_5 is not applicable.

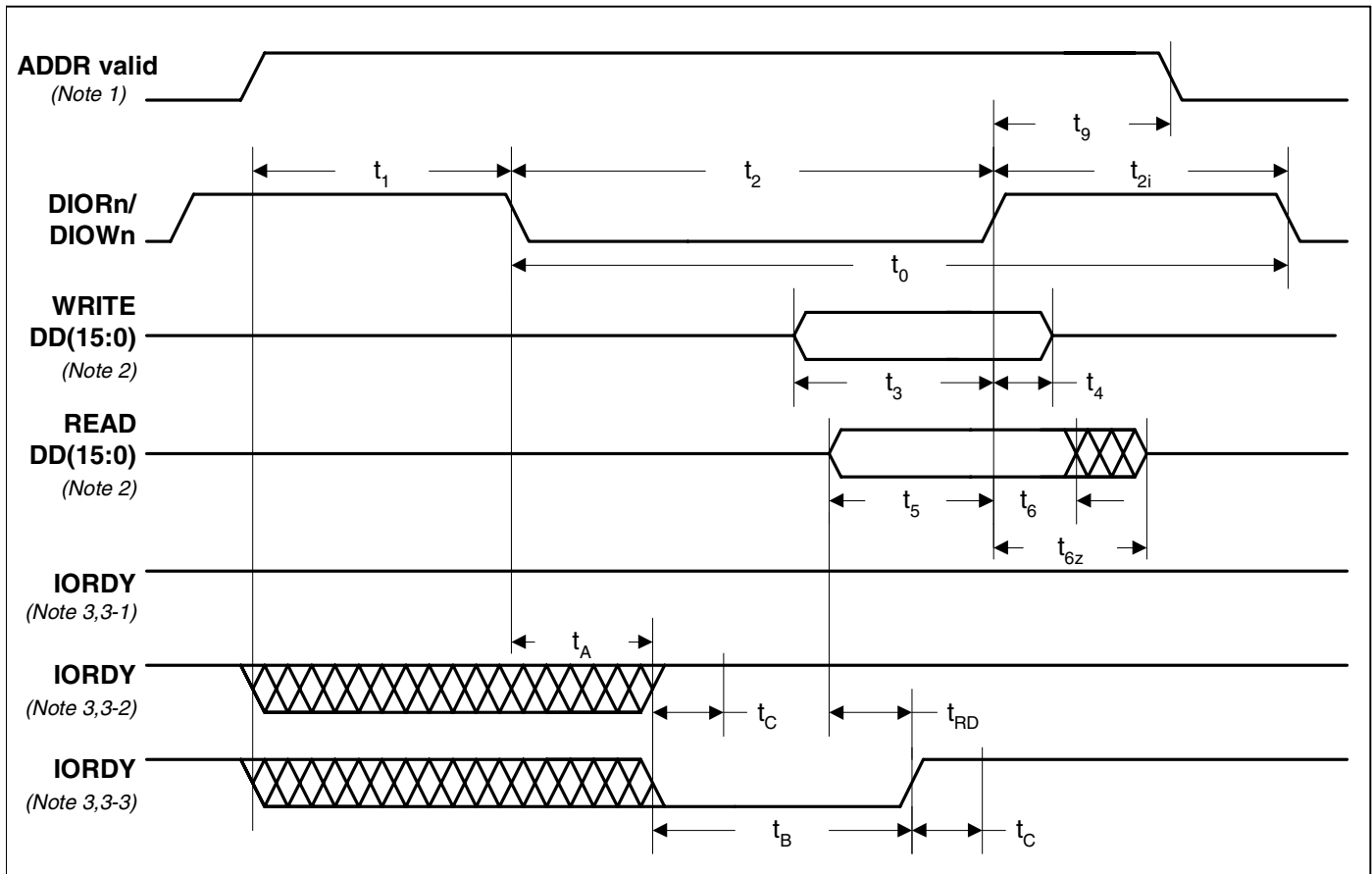

- Note: 1. Device address consists of signals $CS0n$, $CS1n$ and $DA(2:0)$
 2. Data consists of $DD(15:0)$
 3. The negation of $IORDY$ by the device to extend the register transfer cycle. The determination of whether the cycle is to be extended is made by the host after t_A from the assertion of $DIORn$ or $DIOWn$. The assertion and negation of $IORDY$ are described in the following three cases:
 3-1 Device never negates $IORDY$, device keeps $IORDY$ released: no wait is generated.
 3-2 Device negates $IORDY$ before t_A , but causes $IORDY$ to be asserted before t_A . $IORDY$ is released prior to negation and may be asserted for no more than 5 ns before release: no wait generated.
 3-3 Device negates $IORDY$ before t_A . $IORDY$ is released prior to negation and may be asserted for no more than 5 ns before release: wait generated. The cycle completes after $IORDY$ is reasserted. For cycles where a wait is generated and $DIORn$ is asserted, the device shall place read data on $DD(15:0)$ for t_{RD} before asserting $IORDY$.

Figure 19. PIO Data Transfer to/from Device

Multiword DMA Data Transfer

Parameter		Symbol	Mode 0 (in ns)	Mode 1 (in ns)	Mode 2 (in ns)
Cycle time	(min) (Note)	t_0	480	150	120
DIORn / DIOWn asserted pulse width	(min) (Note)	t_D	215	80	70
DIORn data access	(max)	t_E	150	60	50
DIORn data hold	(min)	t_F	5	5	5
DIORn / DIOWn data setup	(min)	t_G	100	30	20
DIOWn data hold	(min)	t_H	20	15	10
DMACKn to DIORn / DIOWn setup	(min)	t_I	0	0	0
DIORn / DIOWn to DMACKn hold	(min)	t_J	20	5	5
CS (1:0) valid to DIORn / DIOWn	(min)	t_M	50	30	25
CS (1:0) hold	(min)	t_N	15	10	10
DMACKn to read data released	(max)	t_Z	20	25	25

Note: t_0 is the minimum total cycle time, t_D is the minimum DIORn / DIOWn assertion time, and t_K (t_{KR} or t_{KW} , as appropriate) is the minimum DIORn / DIOWn negation time. A host shall lengthen t_D and/or t_K to ensure that t_0 is equal to the value reported in the device IDENTIFY DEVICE data. A device implementation shall support any legal host implementation

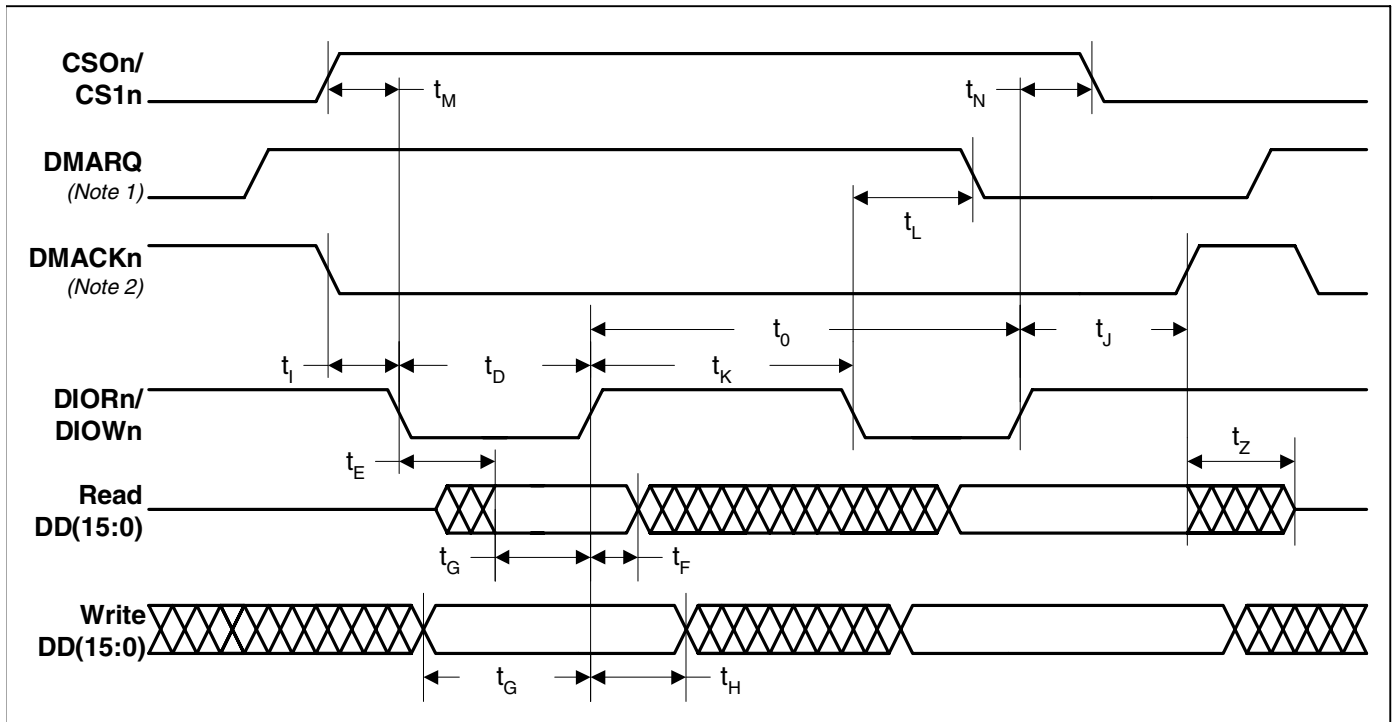

Note: 1. To prevent the transmission of another word of data, the device shall negate DMARQ within the t_L specified time once DMACKn is asserted and reassert it again at a later time to resume the DMA operation. Alternatively, if the device is able to continue the transfer of data, the device may leave DMARQ asserted and wait for the host to reassert DMACKn.
2. This signal may be negated by the Host to suspend the DMA transfer in process.
3. This figure shows the transfer of two words. The actual transfer for a given assertion of DMARQ may be any number of words from one to the remaining number of words to be transferred.

Figure 20. Multiword DMA Data Transfer

Ultra DMA Data Transfer

Figure 21 through Figure 30 define the timings associated with all phases of Ultra DMA bursts. The following table contains the values for the timings for each of the Ultra DMA modes.

Timing reference levels = 1.5 V

Parameter	Symbol	Mode 0 (in ns)		Mode 1 (in ns)		Mode 2 (in ns)		Mode 3 (in ns)		Mode 4 (in ns)	
		min	max	min	max	min	max	min	max	min	max
Typical sustained average two cycle time	$t_{2CYCTYP}$	240	-	160	-	120	-	90	-	60	-
Cycle time allowing for asymmetry and clock variations (from STROBE edge to STROBE edge)	t_{CYC}	112	-	73	-	54	-	39	-	25	-
Two cycle time allowing for clock variations (from rising edge to next rising edge or from falling edge to next falling edge of STROBE)	t_{2CYC}	230	-	154	-	115	-	86	-	57	-
Data setup time at recipient	t_{DS}	15	-	10	-	7	-	7	-	5	-
Data hold time at recipient	t_{DH}	5	-	5	-	5	-	5	-	5	-
Data valid setup time at sender (Note 2) (from data valid until STROBE edge)	t_{DVS}	70	-	48	-	30	-	20	-	6	-
Data valid hold time at sender (Note 2) (from STROBE edge until data may become invalid)	t_{DVH}	6	-	6	-	6	-	6	-	6	-
First STROBE time (for device to first negate DSTROBE from STOP during a data in burst)	t_{FS}	0	230	0	200	0	170	0	130	0	120
Limited interlock time (Note 3)	t_{LI}	0	150	0	150	0	150	0	100	0	100
Interlock time with minimum (Note 3)	t_{MLI}	20	-	20	-	20	-	20	-	20	-
Unlimited interlock time (Note 3)	t_{UI}	0	-	0	-	0	-	0	-	0	-
Maximum time allowed for output drivers to release (from asserted or negated)	t_{AZ}	-	10	-	10	-	10	-	10	-	10
Minimum delay time required for output	t_{ZAH}	20	-	20	-	20	-	20	-	20	-
Drivers to assert or negate (from released)	t_{ZAD}	0	-	0	-	0	-	0	-	0	-
Envelope time (from DMACKn to STOP and HDMARDYn during data in burst initiation and from DMACKn to STOP during data out burst initiation)	t_{ENV}	20	70	20	70	20	70	20	55	20	55
STROBE-to-DMARDYn time (if DMARDYn is negated before this long after STROBE edge, the recipient shall receive no more than one additional data word)	t_{SR}	-	50	-	30	-	20	-	NA	-	NA
Ready-to-final-STROBE time (no STROBE edges shall be sent this long after negation of DMARDYn)	t_{RFS}	-	75	-	70	-	60	-	60	-	60
Ready-to-pause time (that recipient shall wait to pause after negating DMARDYn)	t_{RP}	160	-	125	-	100	-	100	-	100	-
Maximum time before releasing IORDY	t_{IORDYZ}	-	20	-	20	-	20	-	20	-	20
Minimum time before driving STROBE (Note 4)	t_{ZIORDY}	0	-	0	-	0	-	0	-	0	-
Setup and hold times for DMACKn (before assertion or negation)	t_{ACK}	20	-	20	-	20	-	20	-	20	-
Time from STROBE edge to negation of DMARQ or assertion of STOP (when sender terminates a burst)	t_{SS}	50	-	50	-	50	-	50	-	50	-

- Note:
1. Timing parameters shall be measured at the connector of the sender or receiver to which the parameter applies.
 2. The test load for t_{DVS} and t_{DVH} shall be a lumped capacitor load with no cable or receivers. Timing for t_{DVS} and t_{DVH} shall be met for all capacitive loads from 15 to 40 pF where all signals have the same capacitive load value.
 3. t_{UI} , t_{MLI} and t_{LI} indicate sender-to-recipient or recipient-to-sender interlocks, i.e., either sender or recipient is waiting for the other to respond with a signal before proceeding. t_{UI} is an unlimited interlock that has no maximum time value. t_{MLI} is a limited time-out that has a defined minimum. t_{LI} is a limited time-out that has a defined maximum.
 4. t_{ZIORDY} may be greater than t_{ENV} since the device has a pull up on IORDYn giving it a known state when released.

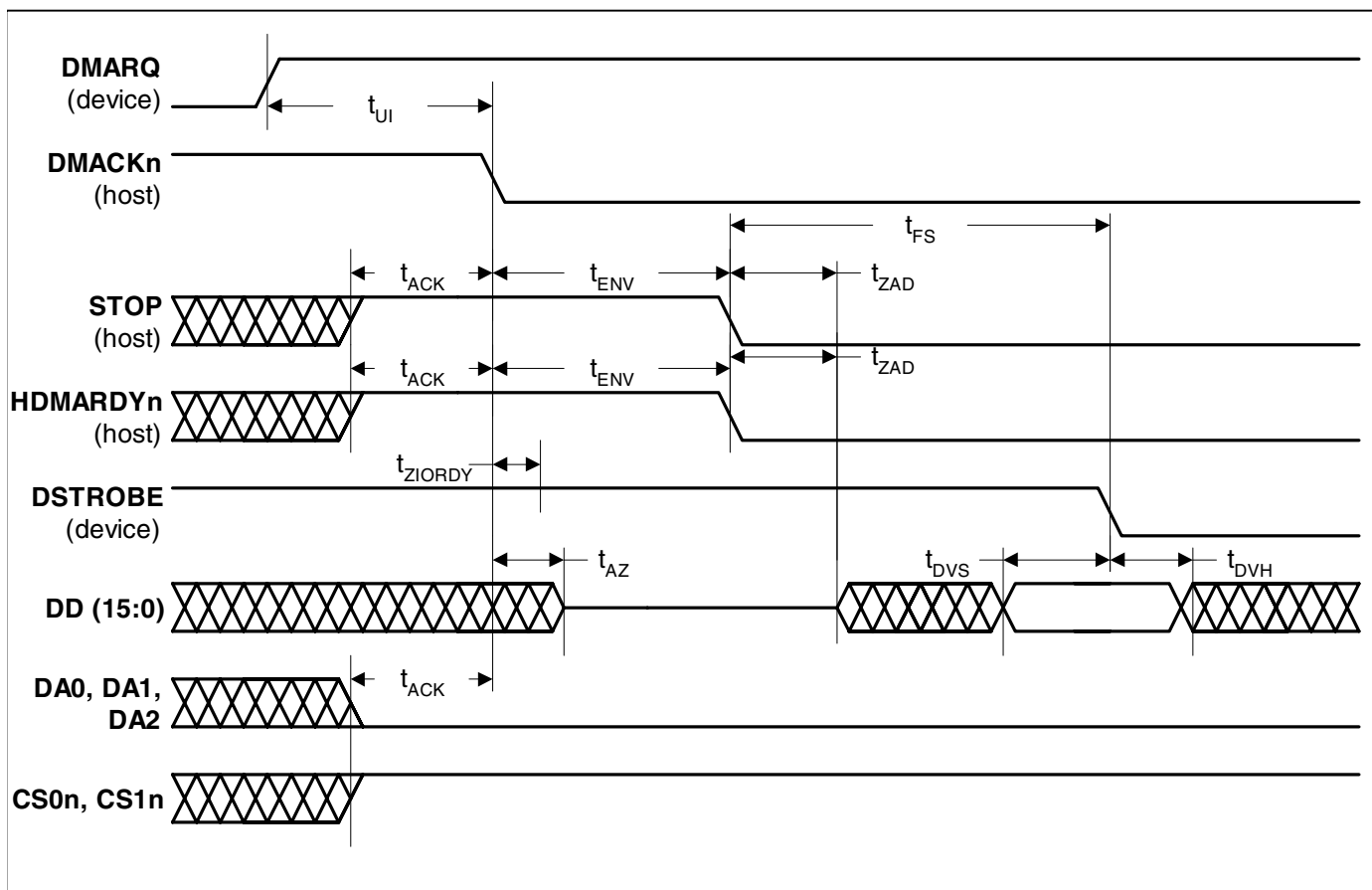

Note: The definitions for the $DIOWn:STOP$, $DIORn:HDMARDYn:HSTROBE$ and $IORDY:DDMARDYn:DSTROBE$ signal lines are not in effect until $DMARQ$ and $DMACKn$ are asserted.

Figure 21. Initiating an Ultra DMA data-in Burst

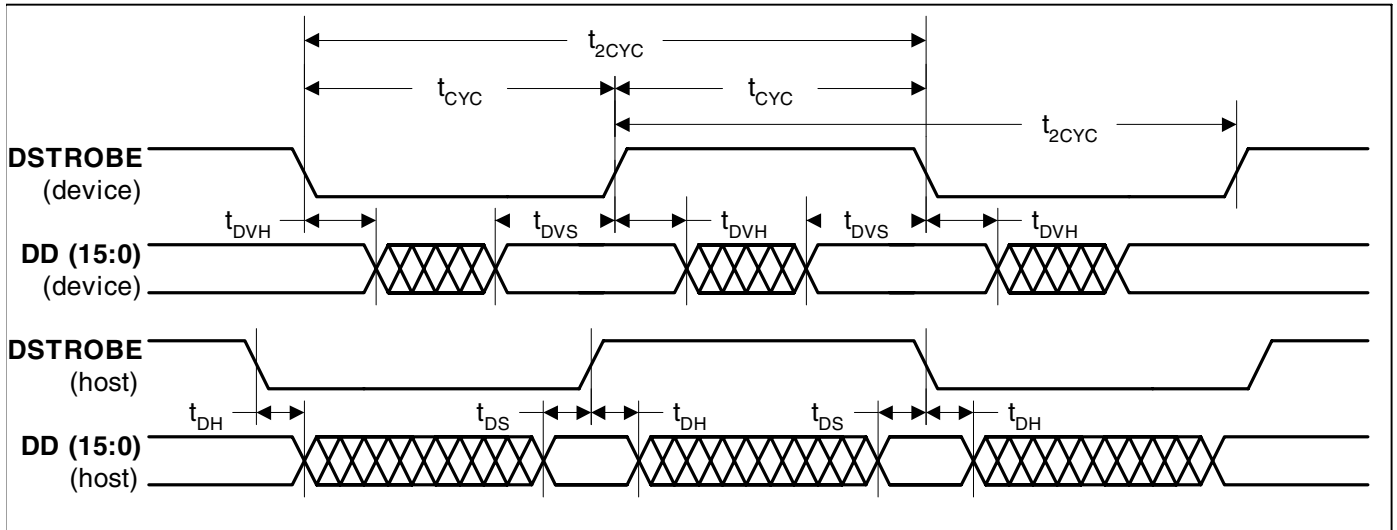

Note: DD (15:0) and DSTROBE signals are shown at both the host and the device to emphasize that cable settling time as well as cable propagation delay shall not allow the data signals to be considered stable at the host until some time after they are driven by the device.

Figure 22. Sustained Ultra DMA data-in Burst

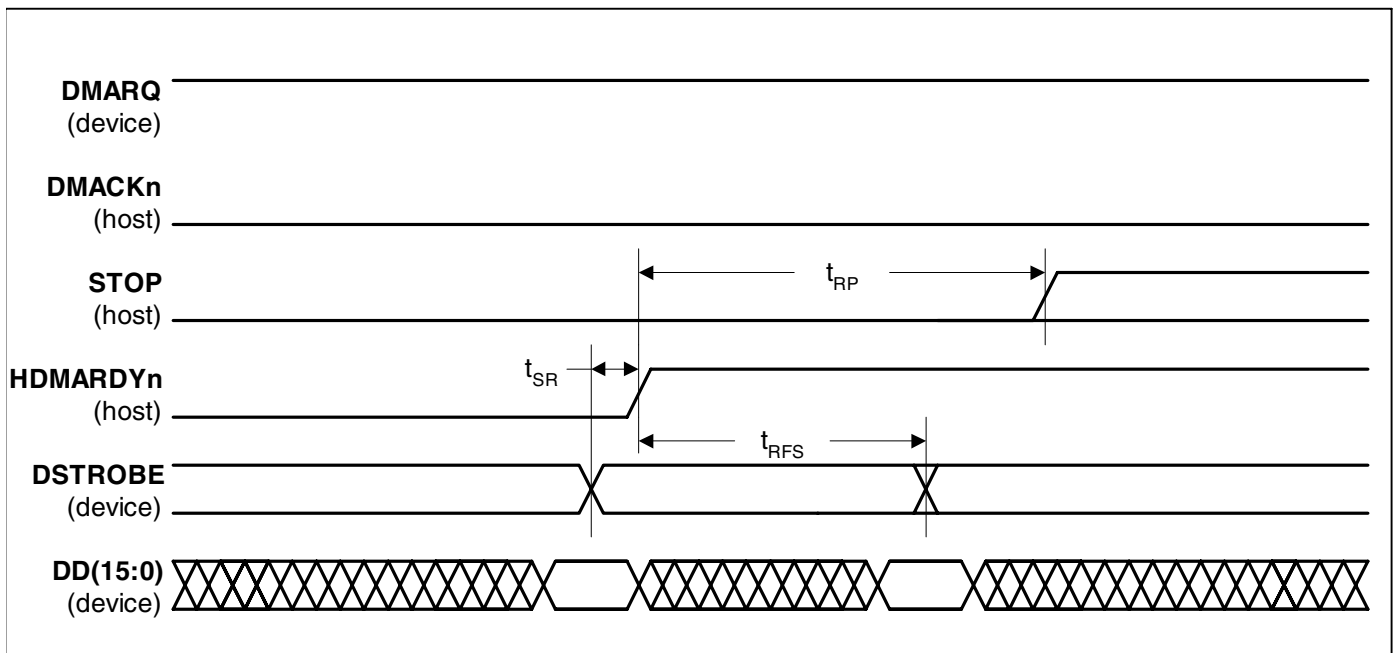
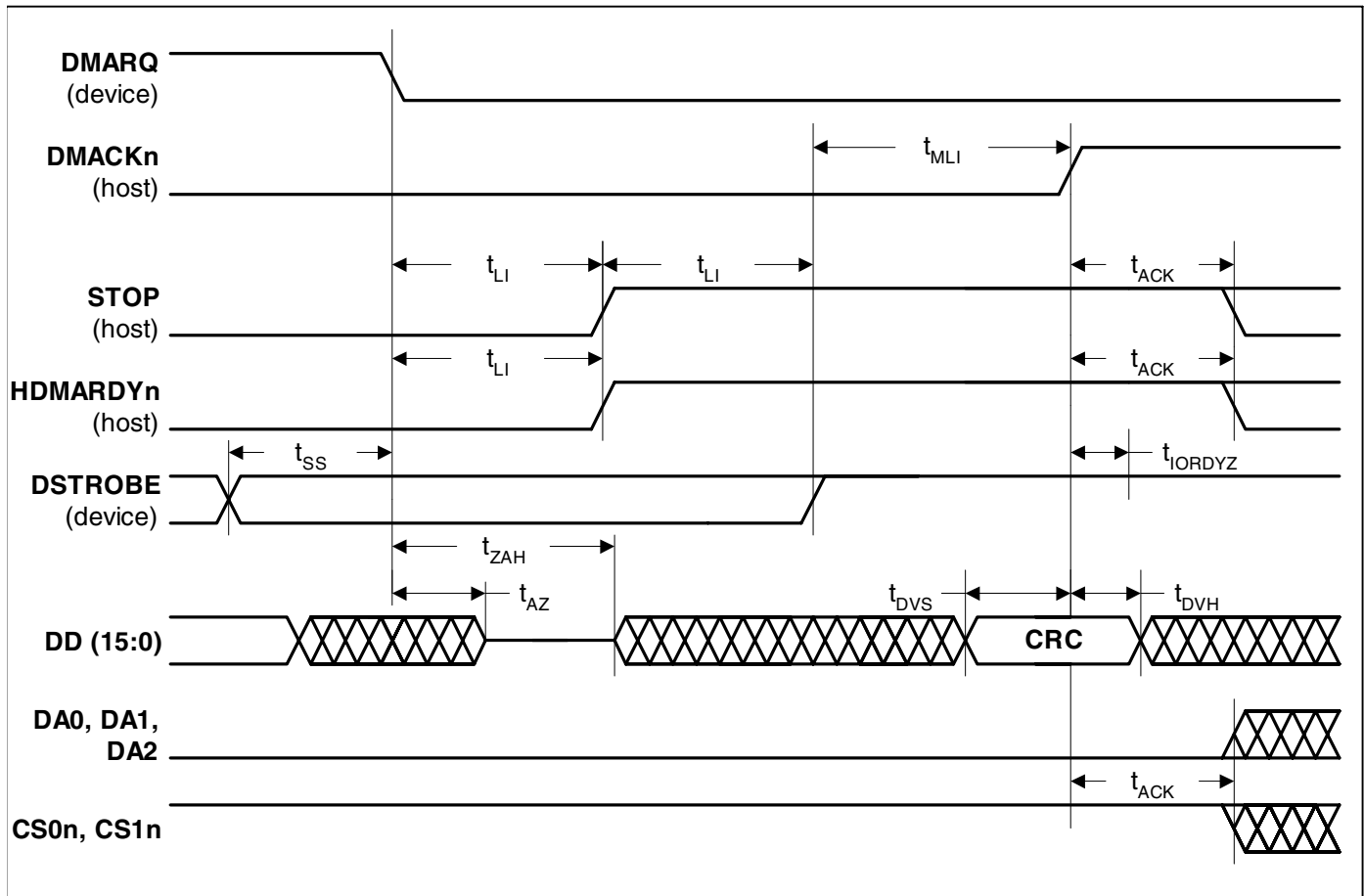
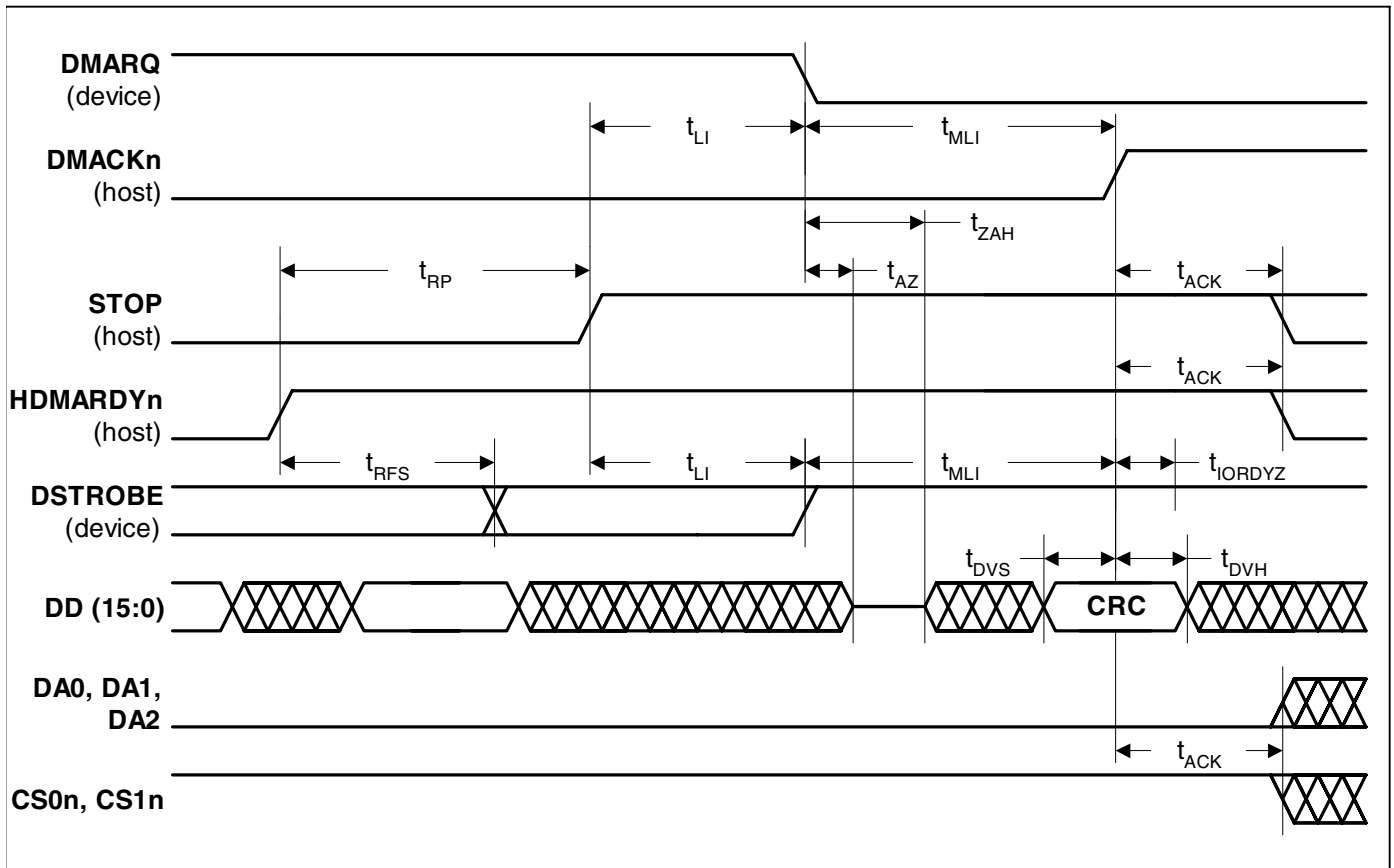

Figure 23. Host Pausing an Ultra DMA data-in Burst



Note: The definitions for the $DIOWn:STOP$, $DIORn:HDMARDYn:HSTROBE$ and $IORDY:DDMARDYn:DSTROBE$ signal lines are no longer in effect after $DMARQ$ and $DMACKn$ are negated.

Figure 24. Device Terminating an Ultra DMA data-in Burst



Note: The definitions for the $DIOWn:STOP$, $DIORn:HDMARDYn:HSTROBE$ and $IORDY:DDMARDYn:DSTROBE$ signal lines are no longer in effect after $DMARQ$ and $DMACKn$ are negated.

Figure 25. Host Terminating an Ultra DMA data-in Burst

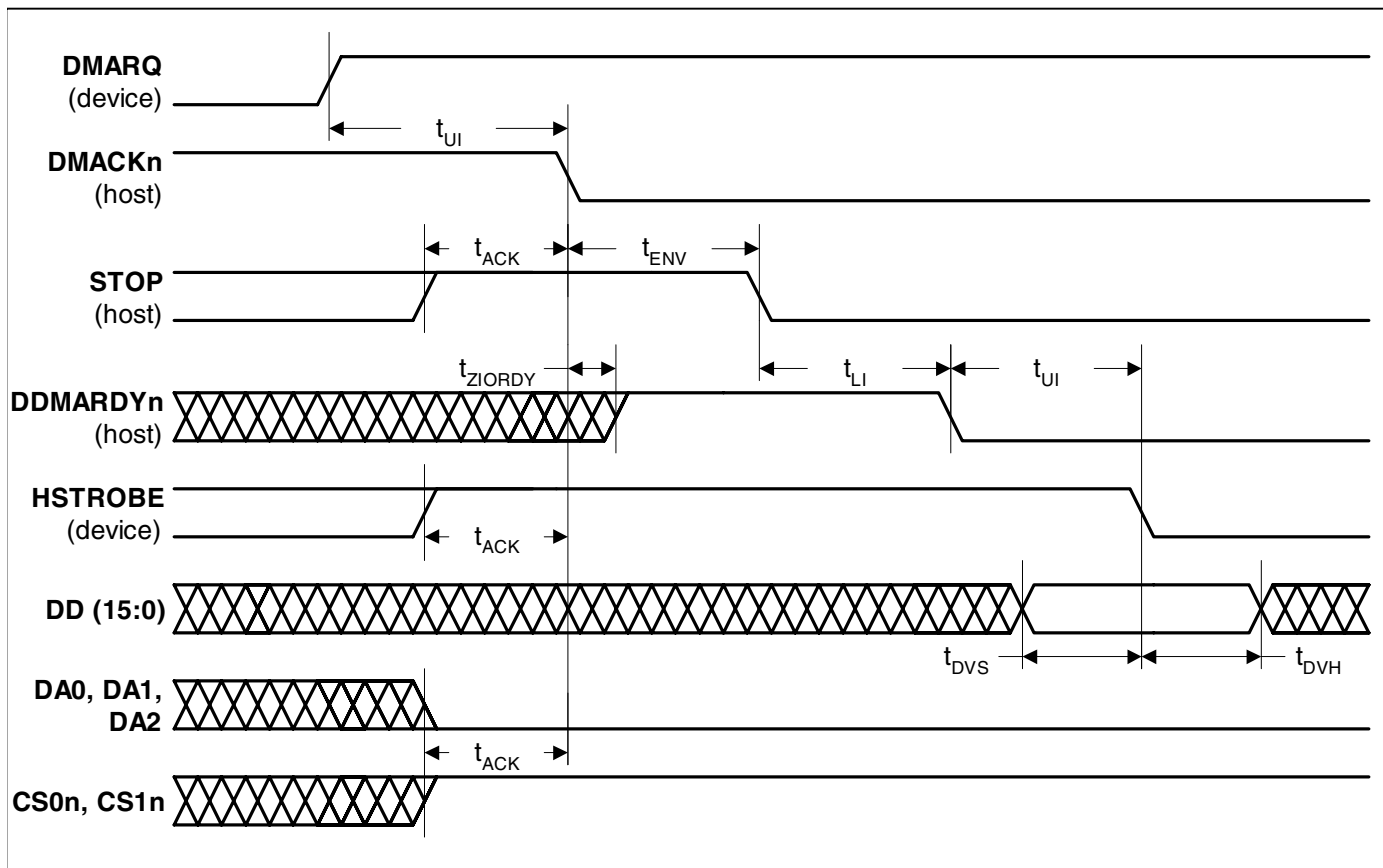

Note: The definitions for the $DIOWn:STOP$, $DIORn:HDMARDYn:HSTROBE$ and $IORDY:DDMARDYn:DSTROBE$ signal lines are not in effect until $DMARQ$ and $DMACKn$ are asserted.

Figure 26. Initiating an Ultra DMA data-out Burst

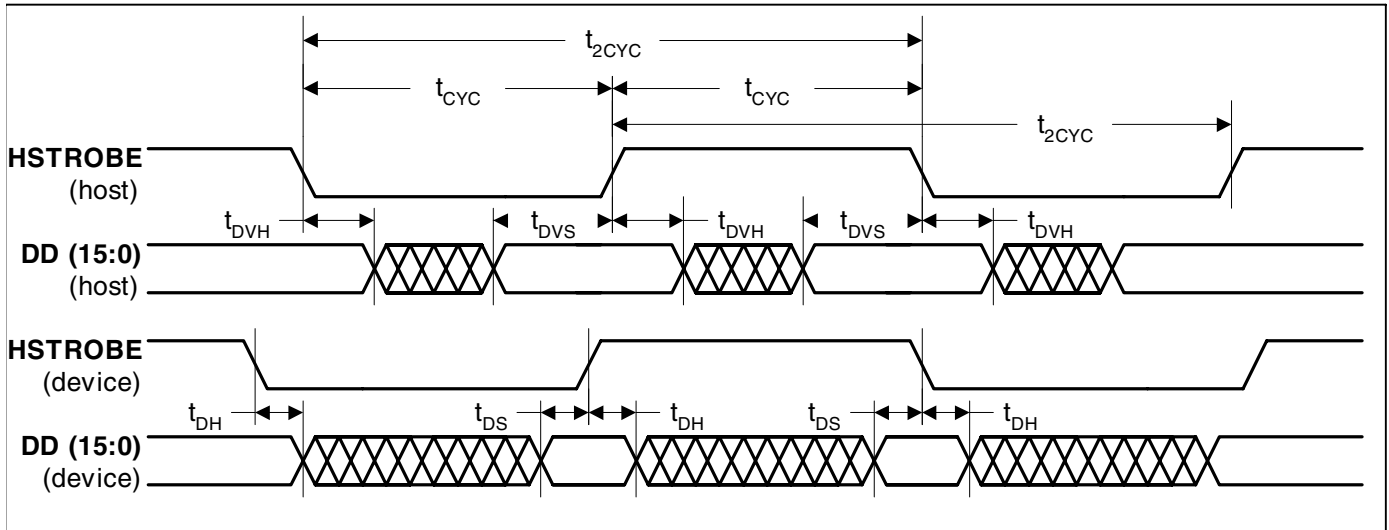

Note: DD (15:0) and HSTROBE signals are shown at both the device and the host to emphasize that cable settling time as well as cable propagation delay shall not allow the data signals to be considered stable at the device until some time after they are driven by the host.

Figure 27. Sustained Ultra DMA data-out Burst

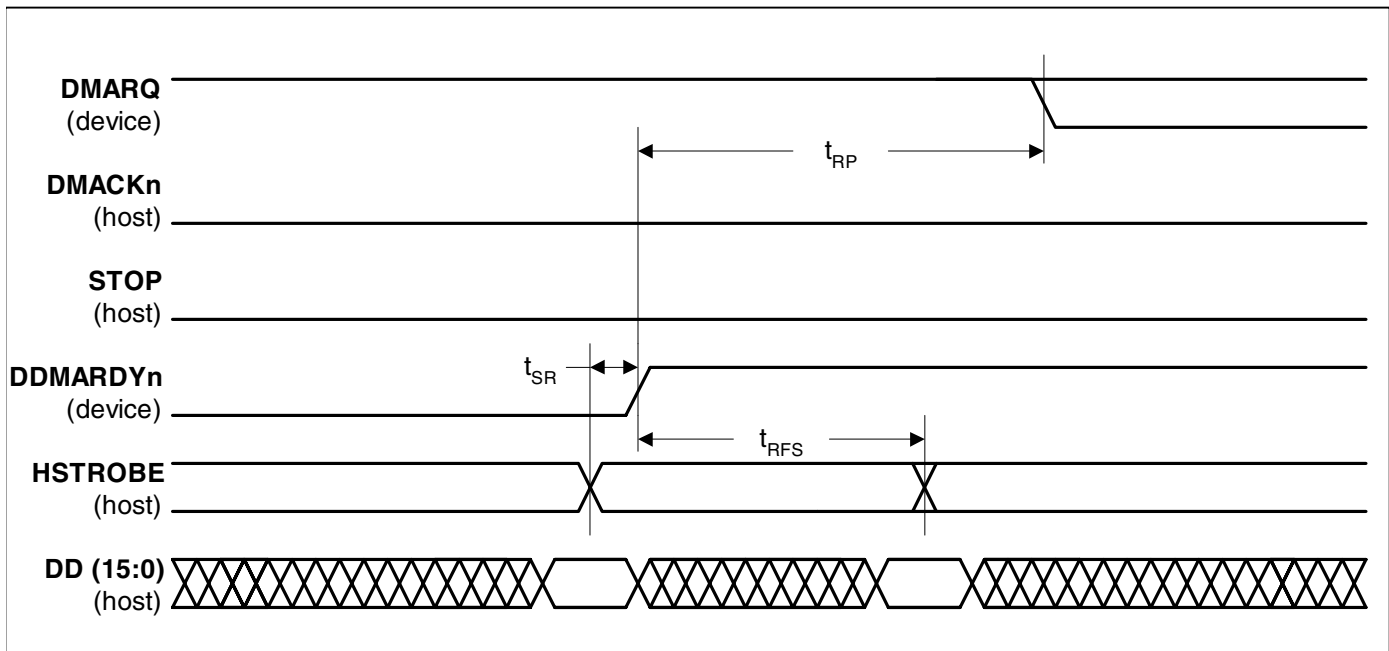

Note: 1. The device may negate DMARQ to request termination of the Ultra DMA burst no sooner than t_{RP} after DDMARDYn is negated.
2. If the t_{SR} timing is not satisfied, the device may receive zero, one, or two more data words from the host.

Figure 28. Device Pausing an Ultra DMA data-out Burst

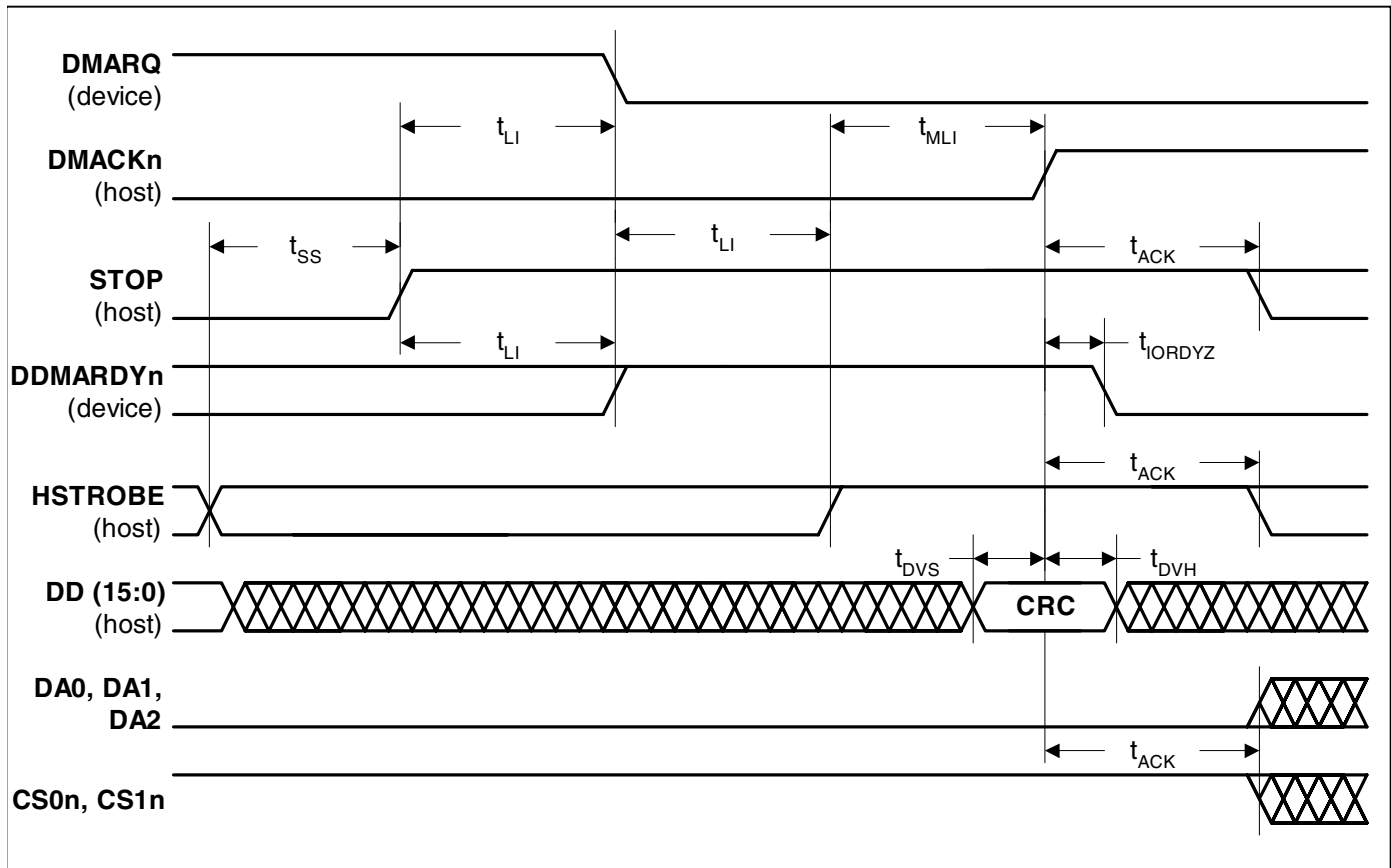

Note: The definitions for the $DIOWn:STOP$, $IORDY:DDMARDYn:DSTROBE$ and $DIORn:HDMARDYn:HSTROBE$ signal lines are no longer in effect after $DMARQ$ and $DMACKn$ are negated.

Figure 29. Host Terminating an Ultra DMA data-out Burst

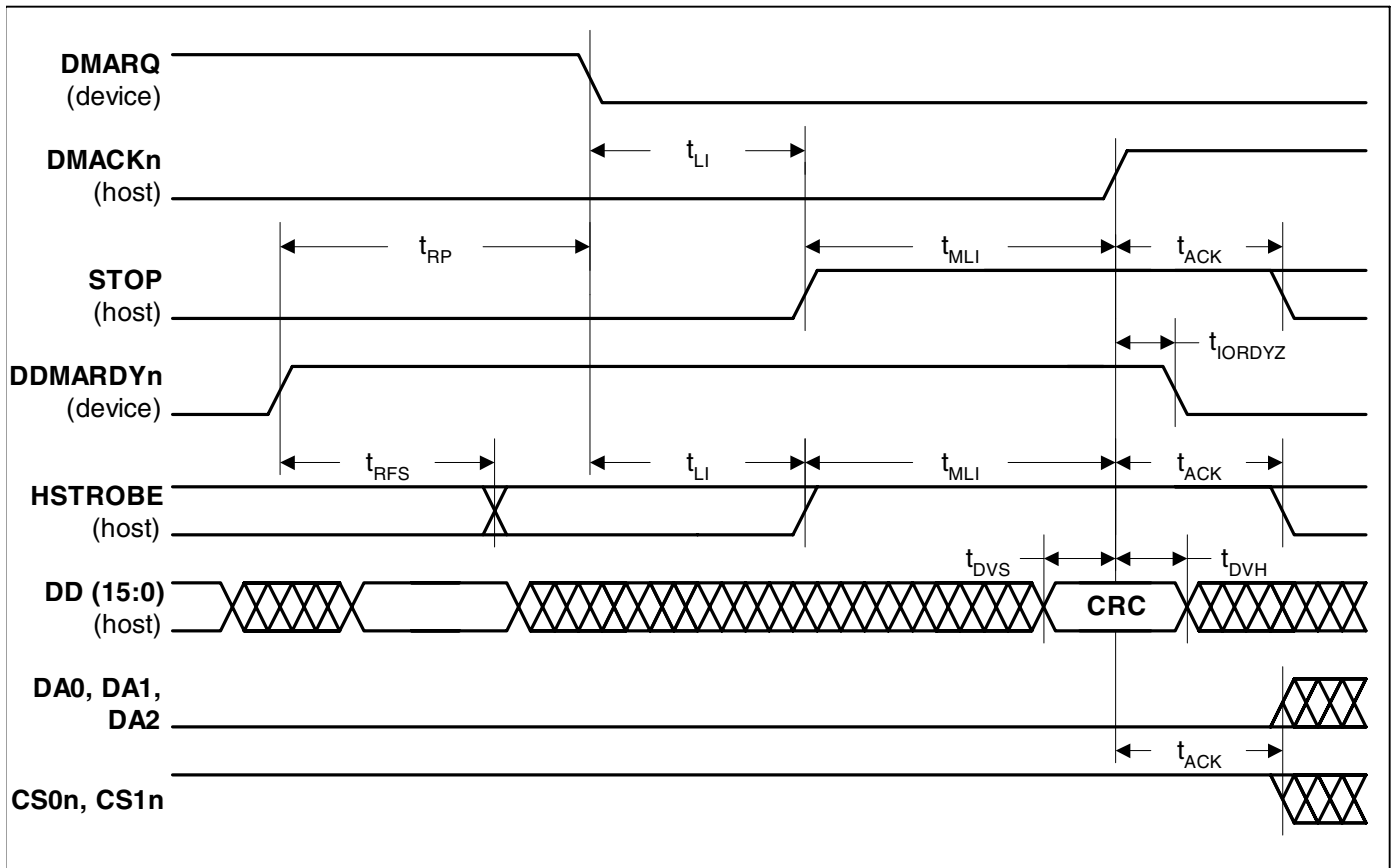

Note: The definitions for the $DIOWn:STOP$, $IORDY:DDMARDYn:DSTROBE$ and $DIORn:HDMARDYn:HSTROBE$ signal lines are no longer in effect after $DMARQ$ and $DMACKn$ are negated.

Figure 30. Device Terminating an Ultra DMA data-out Burst

Ethernet MAC Interface

Parameter	Symbol	Min		Typ		Max		Unit
		10 Mbit mode	100 Mbit mode	10 Mbit mode	100 Mbit mode	10 Mbit mode	100 Mbit mode	
TXCLK cycle time	t_{TX_per}	-	-	400	40	-	-	ns
TXCLK high time	t_{TX_high}	140	14	200	20	260	26	ns
TXCLK low time	t_{TX_low}	140	14	200	20	260	26	ns
TXCLK to signal transition delay time	t_{TXd}	0	0	10	10	25	25	ns
TXCLK rise/fall time	t_{TXrf}	-	-	-	-	5	5	ns
RXCLK cycle time	t_{RX_per}	-	-	400	40	-	-	ns
RXCLK high time	t_{RX_high}	140	14	200	20	260	26	ns
RXCLK low time	t_{RX_low}	140	14	200	20	260	26	ns
RXDVAL / RXERR setup time	t_{RXs}	10	10	-	-	-	-	ns
RXDVAL / RXERR hold time	t_{RXh}	10	10	-	-	-	-	ns
RXCLK rise/fall time	t_{RXrf}	-	-	-	-	5	5	ns
MDC cycle time	t_{MDC_per}	400	400	-	-	-	-	ns
MDC high time	t_{MDC_high}	160	160	-	-	-	-	ns
MDC low time	t_{MDC_low}	160	160	-	-	-	-	ns
MDC rise/fall time	t_{MDCrf}	-	-	-	-	5	5	ns
MDIO setup time (STA sourced)	t_{MDIOs}	10	10	15	15	-	-	ns
MDIO hold time (STA sourced)	t_{MDIOh}	10	10	15	15	-	-	ns
MDC to MDIO signal transition delay time (PHY sourced)	t_{MDIOd}	-	-	-	-	300	300	ns

STA - Station - Any device that contains an IEEE 802.11 conforming Medium Access Control (MAC) and physical layer (PHY) interface to the wireless medium.

PHY - Ethernet physical layer interface.

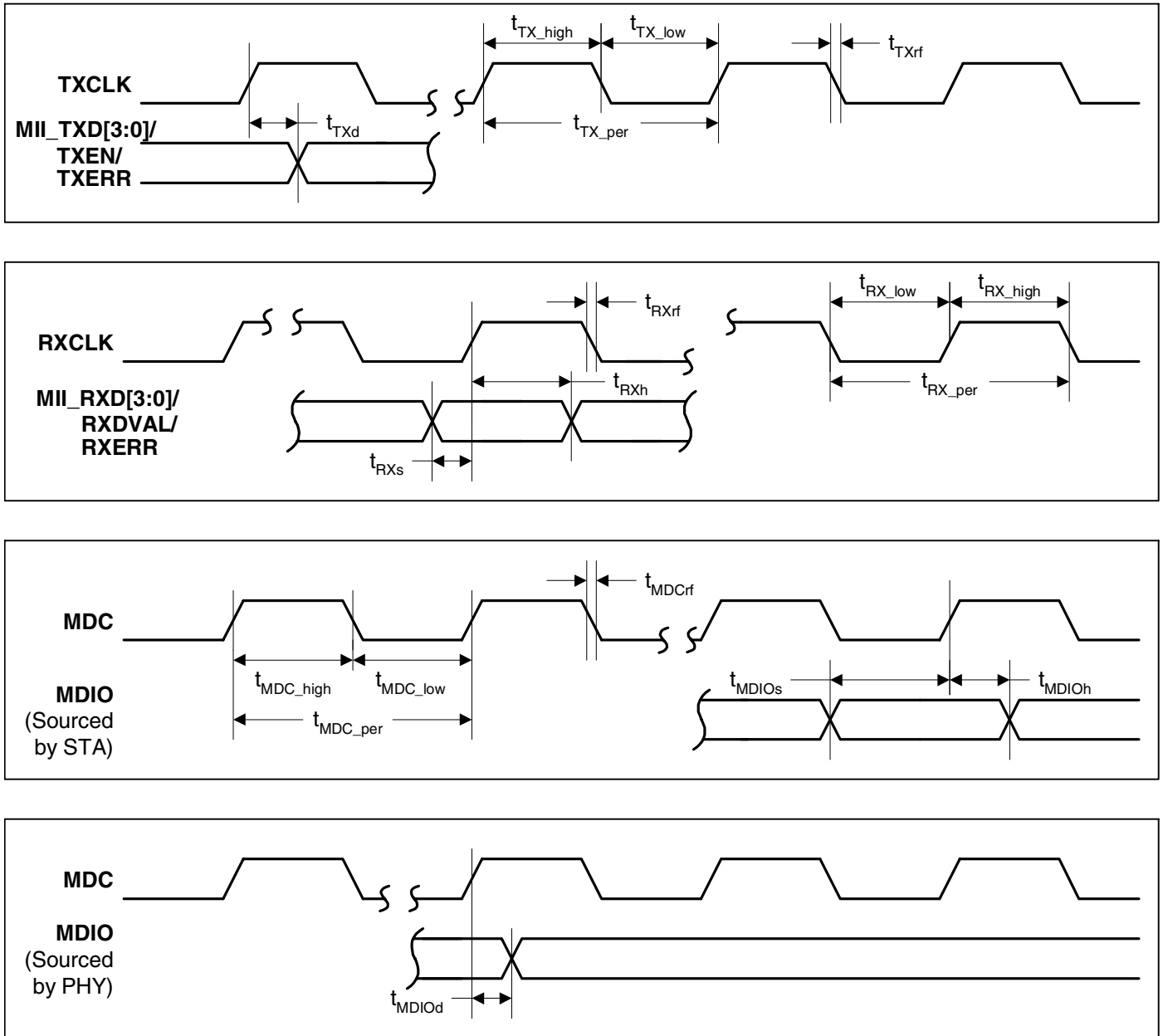

Figure 31. Ethernet MAC Timing Measurement

Audio Interface

The following table contains the values for the timings of each of the SPI modes.

Parameter	Symbol	Min	Typ	Max	Unit
SCLK cycle time	t_{clk_per}	-	t_{spix_clk}	-	ns
SCLK high time	t_{clk_high}	-	$(t_{spix_clk}) / 2$	-	ns
SCLK low time	t_{clk_low}	-	$(t_{spix_clk}) / 2$	-	ns
SCLK rise/fall time	t_{clkrf}	-	4.5 / 1.5	-	ns
Data from master valid delay time	t_{DMd}	-	2	-	ns
Data from master setup time	t_{DMs}	-	20	-	ns
Data from master hold time	t_{DMh}	-	40	-	ns
Data from slave valid delay time	t_{DSd}	-	2	-	ns
Data from slave setup time	t_{DSs}	-	20	-	ns
Data from slave hold time	t_{DSh}	-	40	-	ns

Note: The t_{spix_clk} is programmable by the user.

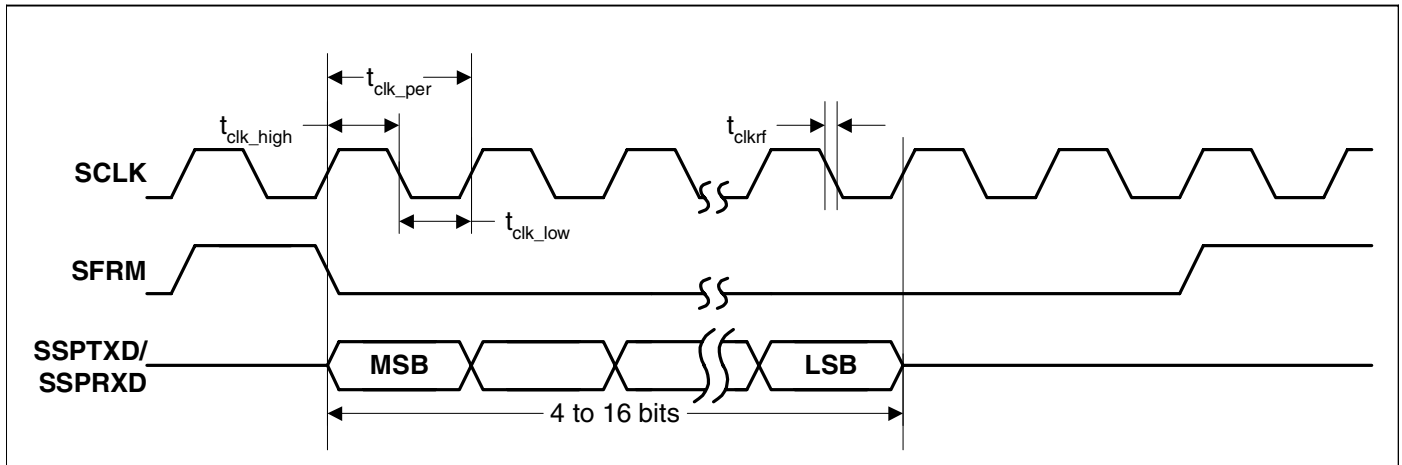
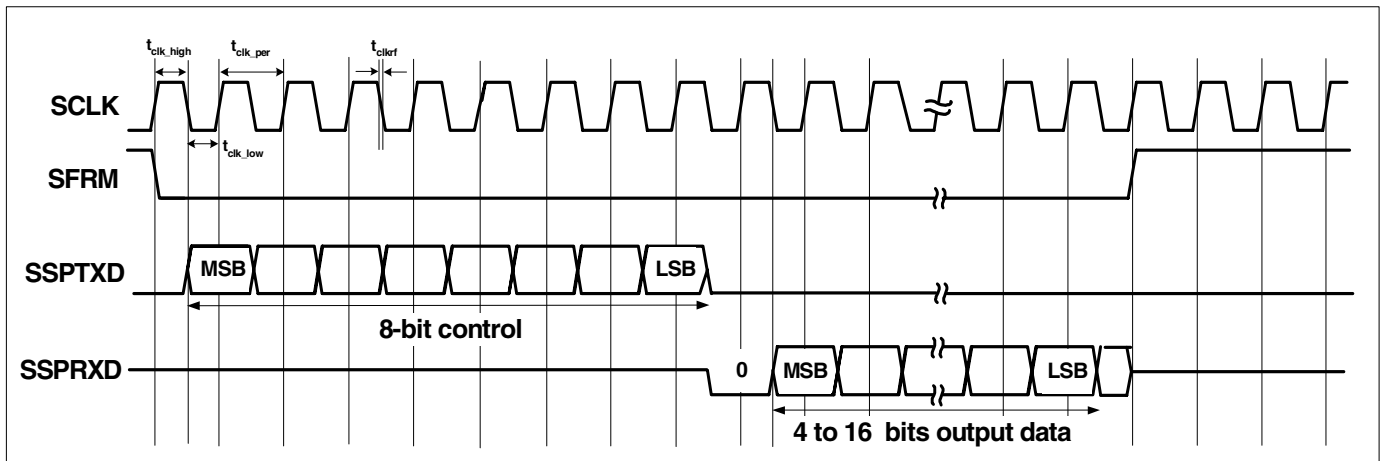
Texas Instruments' Synchronous Serial Format

Figure 32. SPI Single Transfer Timing Measurement
Microwire

Figure 33. Microwire Frame Format, Single Transfer

Motorola SPI

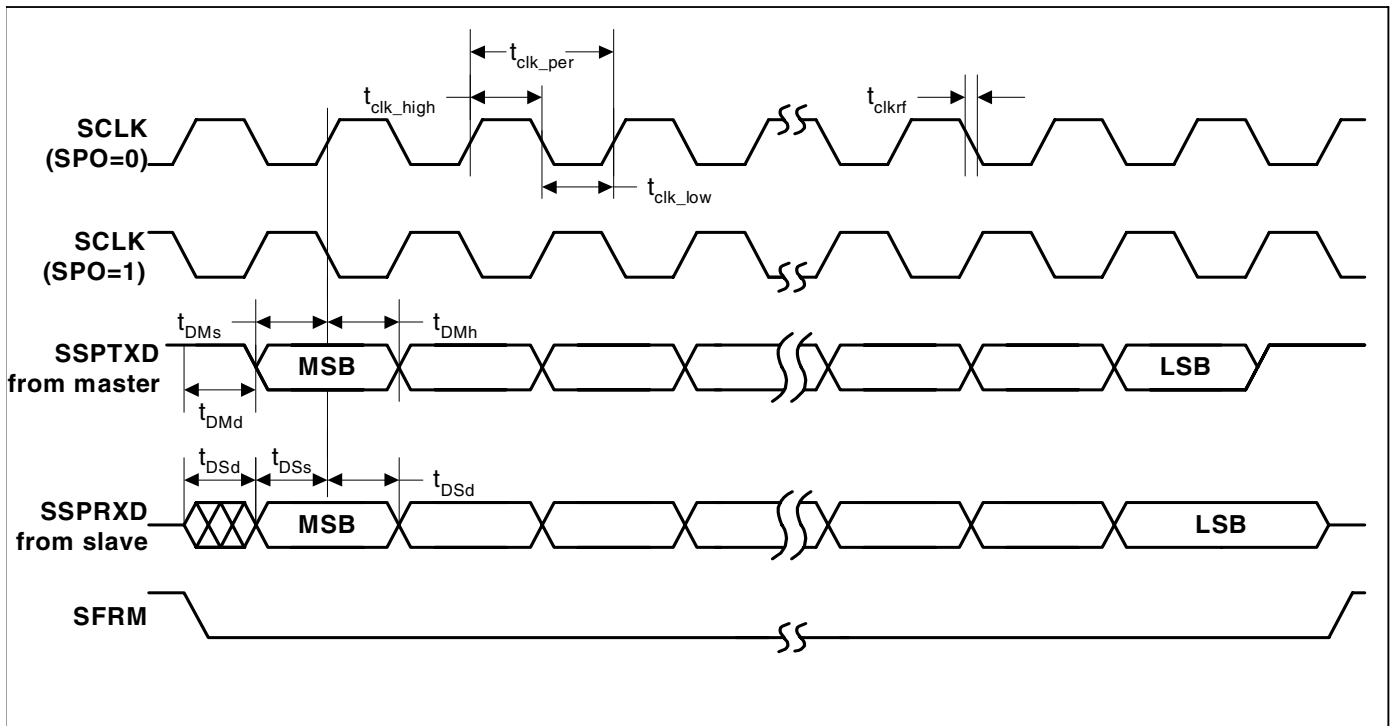

Figure 34. SPI Format with SPH=1 Timing Measurement

Inter-IC Sound - I²S

Parameter	Symbol	Min	Typ	Max	Unit
SCLK cycle time	t_{clk_per}	-	t_{i2s_clk}	-	ns
SCLK high time	t_{clk_high}	-	$(t_{i2s_clk}) / 2$	-	ns
SCLK low time	t_{clk_low}	-	$(t_{i2s_clk}) / 2$	-	ns
SCLK rise/fall time	t_{clkrf}	-	4	-	ns
SCLK to LRCLK assert delay time	t_{LRs}	-	1.5	-	ns
LRCLK from SCLK assert hold time	t_{LRh}	-	1.5	-	ns
SDI to SCLK deassert setup time	t_{SDIs}	-	20	-	ns
SDI from SCLK deassert hold time	t_{SDIh}	-	10	-	ns
SCLK to SDO assert delay time	t_{SDOd}	-	4	-	ns
SDO from SCLK assert hold time	t_{SDOh}	-	4	-	ns

Note: t_{i2s_clk} is programmable by the user.

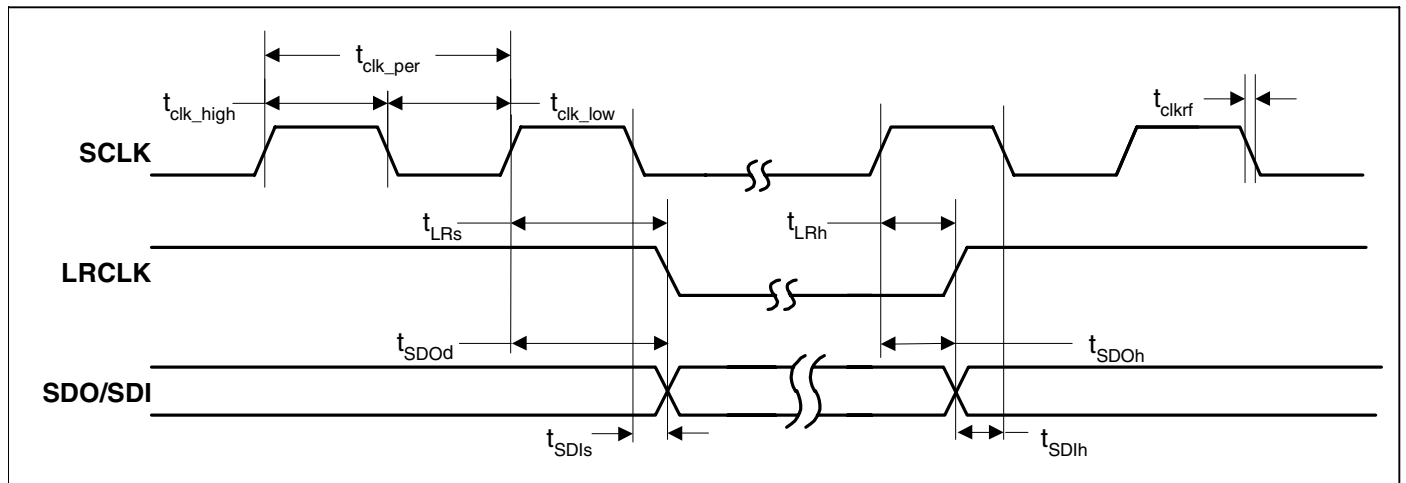

Figure 35. Inter-IC Sound (I²S) Timing Measurement

AC'97

Parameter	Symbol	Min	Typ	Max	Unit
ABITCLK input cycle time	t_{clk_per}	-	81.4	-	ns
ABITCLK input high time	t_{clk_high}	36	-	45	ns
ABITCLK input low time	t_{clk_low}	36	-	45	ns
ABITCLK input rise time	t_{clkr}	2	-	6	ns
ABITCLK input fall time	t_{clkf}	2	-	6	ns
ASDI setup to ABITCLK falling	t_s	10	23	-	ns
ASDI hold after ABITCLK falling	t_h	10	53	-	ns
ASDI input rise/fall time	t_{rfin}	2	-	6	ns
ABITCLK rising to ASDO / ASYNC valid, $C_L = 55$ pF	t_{co}	2	-	15	ns
ASYNC / ASDO rise time, $C_L = 55$ pF	t_{rout}	2	-	6	ns
ASYNC / ASDO fall time, $C_L = 55$ pF	t_{fout}	2	-	6	ns

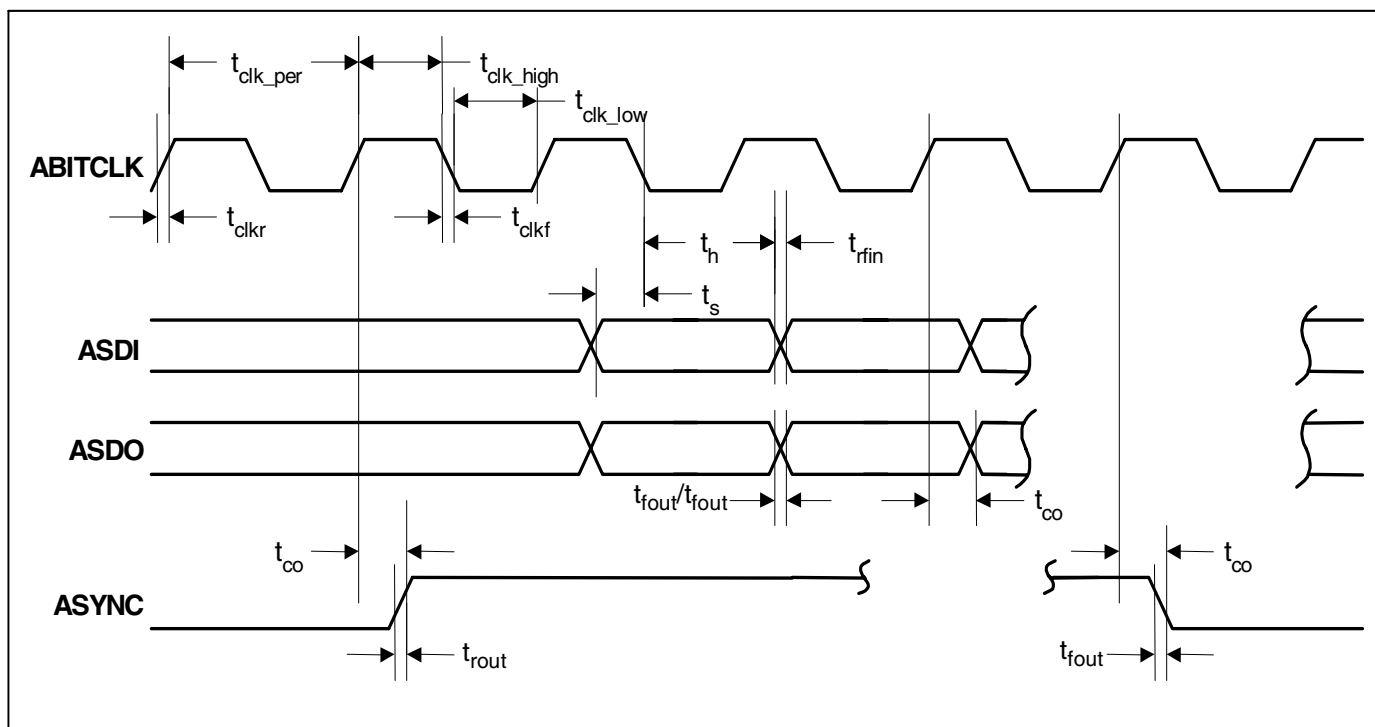

Figure 36. AC '97 Configuration Timing Measurement

LCD Interface

Parameter	Symbol	Min	Typ	Max	Unit
SPCLK rising time	t_{clkr}	-	5	-	ns
SPCLK falling time	t_{clkf}	-	5	-	ns
SPCLK rising edge to control signal transition time	t_{CD}	-	1	-	ns
SPCLK rising edge to data transition time	t_{DD}	-	0	-	ns
SPCLK falling edge to control signal transition time	t_{CDi}	-	$(t_{SPCLK}) / 2$	-	ns
SPCLK falling edge to data transition time	t_{DDi}	-	$(t_{SPCLK}) / 2$	-	ns
Data valid time	t_{Dv}	-	t_{SPCLK}	-	ns

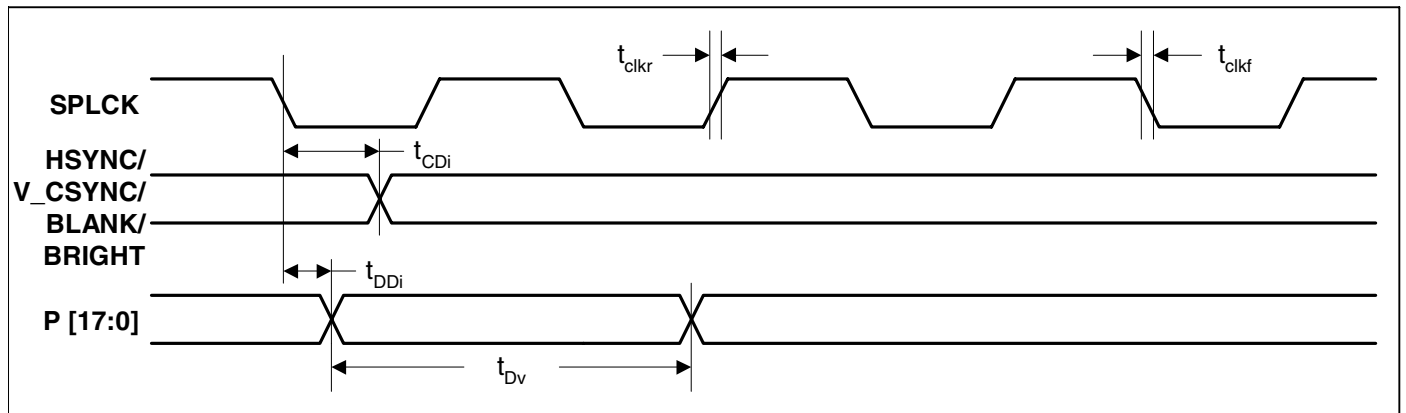
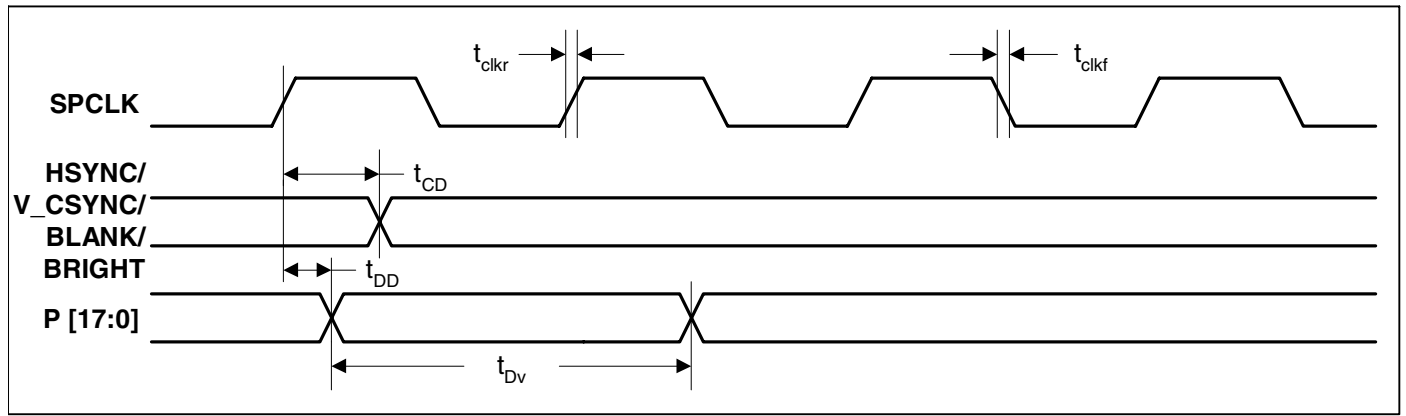
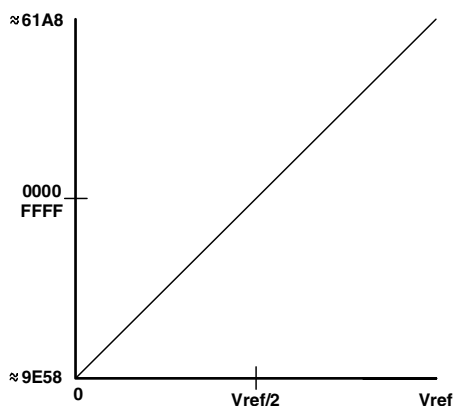

Figure 37. LCD Timing Measurement

ADC

Parameter	Comment	Value	Units
Resolution	No missing codes Range of 0 to 3.3 V	50K counts (approximate)	
Integral non-linearity		0.01%	
Offset error		±15	mV
Full scale error		0.2%	
Maximum sample rate	ADIV = 0 ADIV = 1	3750 925	Samples per second Samples per second
Channel switch settling time	ADIV = 0 ADIV = 1	500 2	µs ms
Noise (RMS) - typical		120	µV

Note: ADIV refers to bit 16 in the KeyTchClkDiv register.
 ADIV = 0 means the input clock to the ADC module is equal to the external 14.7456 MHz clock divided by 4.
 ADIV = 1 means the input clock to the ADC module is equal to the external 14.7456 MHz clock divided by 16.



A/D Converter Transfer Function
(approximately ±25,000 counts)

Figure 38. ADC Transfer Function

Using the ADC:

This ADC has a state-machine based conversion engine that automates the conversion process. The initiator for a conversion is the read access of the TSXYResult register by the CPU. The data returned from reading this register contains the result as well as the status bit indicating the state of the ADC. However, this peripheral requires a delay between each successful conversion and the issue of the next conversion command, or else the returned value of successive samples may not reflect the analog input. Since the state of the ADC state machine is returned through the same channel used to initiate the conversion process, there must be a delay inserted after every complete conversion. Note that reading TSXYResult during a conversion will not affect the result of the ongoing process.

The following is a recommended procedure for safely polling the ADC from software:

1. Read the TSXYResult register into a local variable to initiate a conversion.
2. If the value of bit 31 of the local variable is '0' then repeat step 1.
3. Delay long enough to meet the maximum sample rate as shown above.
4. Mask the local variable with 0xFFFF to remove extraneous data.
5. If signed mode is used, do a sign extend of the lower halfword.
6. Return the sampled value.

JTAG

Parameter	Symbol	Min	Max	Units
TCK clock period	t_{clk_per}	100	-	ns
TCK clock high time	t_{clk_high}	50	-	ns
TCK clock low time	t_{clk_low}	50	-	ns
TMS / TDI to clock rising setup time	t_{JP_s}	20	-	ns
Clock rising to TMS / TDI hold time	t_{JP_h}	45	-	ns
JTAG port clock to output	$t_{JP_{co}}$	-	30	ns
JTAG port high impedance to valid output	$t_{JP_{zx}}$	-	30	ns
JTAG port valid output to high impedance	$t_{JP_{xz}}$	-	30	ns

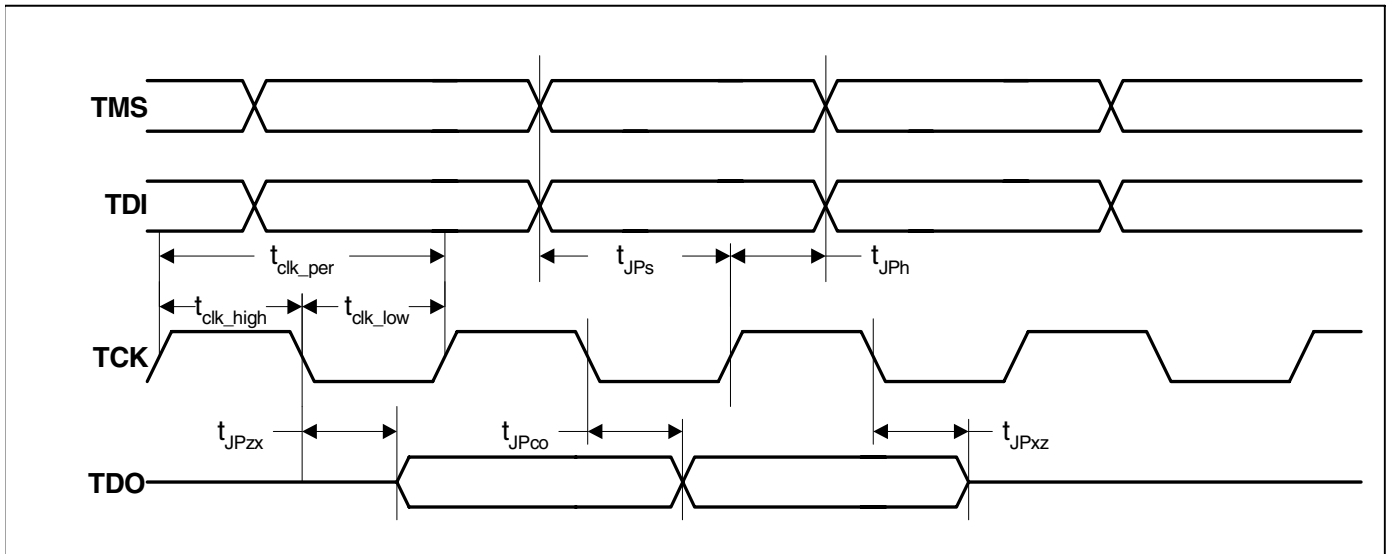

Figure 39. JTAG Timing Measurement

352 Pin BGA Package Outline

352-Ball PBGA Diagram

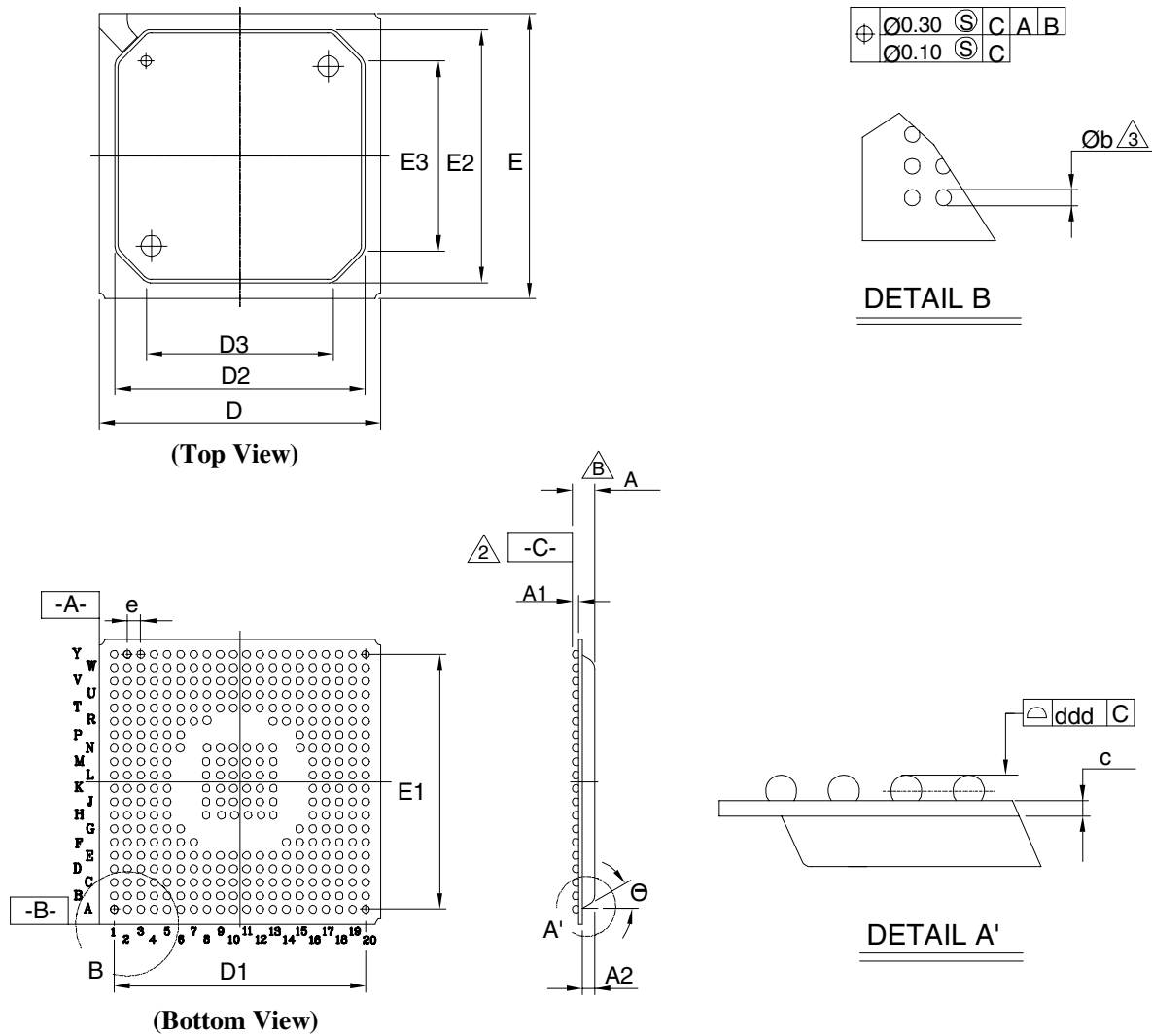

Figure 40. 352 Pin PBGA Pin Diagram

Table R. 352 Pin Diagram Dimensions

Symbol	dimension in mm			dimension in inches		
	MIN	NOM	MAX	MIN	NOM	MAX
A	2.20	2.30	2.50	0.087	0.092	0.098
A1	-	0.60	-	-	0.024	-
A2	1.12	1.17	1.22	0.044	0.046	0.048
b	-	0.75	-	-	0.030	-
c	0.51	0.56	0.61	0.020	0.022	0.024
D	26.80	27.00	27.20	1.055	1.063	1.071
D1	-	24.13	-	-	0.950	-
D2	23.80	24.00	24.20	0.937	0.945	0.953
D3	17.95	18.00	18.05	0.707	0.709	0.711
E	26.80	27.00	27.20	1.055	1.063	1.071
E1	-	24.13	-	-	0.950	-
E2	23.80	24.00	24.20	0.937	0.945	0.953
E3	17.95	18.00	18.05	0.707	0.709	0.711
e	-	1.27	-	-	0.050	-
ddd	-	-	0.15	-	-	0.006
q	30° TYP			30° TYP		

- Note:*
1. Controlling Dimension: Millimeter.
 2. Primary Datum C and seating plane are defined by the spherical crowns of the solder balls.
 3. Dimension b is measured at the maximum solder ball diameter, parallel to Primary Datum C.
 4. There shall be a minimum clearance of 0.25 mm between the edge of the solder ball and the body edge.
 5. Reference Document: JEDEC MO-151, BAL-2

352 Pin BGA Pinout (Bottom View)

The following table shows the 352 pin BGA pinout. (For better understanding, compare the coordinates on the x and y axis on Figure 40, "352 PIN BGA PINOUT", on page 58 with Figure 40, "352 Pin PBGA Pin Diagram", on page 56.

- VDD_core is CVDD.
- VDD_ring is RVDD.
- All core and ring grounds are connected together and are labelled GND.
- Other special power requirements are clearly labelled (i.e. H18=ADC_VDD and H19=ADC_GND).
- NC means that the pin is not connected.

Figure 40. 352 PIN BGA PINOUT

	1	2	3	4	5	6	7	8	9	10	11	12	13	14	15	16	17	18	19	20		
Y	HSYNC	DD[1]	DD[12]	P[2]	AD[15]	DA[6]	DA[4]	AD[10]	DA[1]	AD[8]	IDEDA[0]	DTRN	TDO	BOOT[0]	EEDAT	ASDO	SFRM1	RDLED	USBP[1]	ABITCLK	Y	
W	P[12]	P[9]	DD[0]	P[5]	P[3]	DA[7]	DA[5]	AD[11]	AD[9]	IDECSEN	IDEDA[1]	TCK	TMS	EECLK	SCLK1	GRLED	INT[3]	SLA[1]	SLA[0]	RXD[2]	W	
V	P[16]	P[11]	P[8]	DD[15]	DD[13]	P[1]	AD[14]	AD[12]	DA[2]	IDECSEN	IDEDA[2]	TDI	GND	ASYN	SSPTX1	INT[2]	RTSN	USBP[0]	CTSN	TXD[0]	V	
U	AD[0]	P[15]	P[10]	P[7]	P[6]	P[4]	P[0]	AD[13]	DA[3]	DA[0]	DSRN	BOOT[1]	NC	SSPRX1	INT[1]	PWMOUT	USBM[0]	RXD[1]	TXD[1]	ROW[1]	U	
T	DA[8]	BLANK	P[13]	SPCLK	V_CSYN	DD[4]	GND	CVD	RVDD	GND	GND	RVDD	CVDD	GND	INT[0]	USBM[1]	RXD[0]	TXD[2]	ROW[2]	ROW[4]	T	
R	AD[2]	AD[1]	P[17]	P[14]	RVDD	RVD	GND	CVD					CVDD	GND	RVDD	RVDD	ROW[0]	ROW[3]	PLL_GND	ROW[5]	R	
P	AD[4]	DA[10]	DA[9]	BRIGHT	RVDD	RVD									RVDD	RVDD	XTALI	PLL_VDD	ROW[6]	ROW[7]	P	
N	DA[13]	DA[12]	DA[11]	AD[3]	CVDD	CVD		GND	GND	GND	GND	GND	GND		GND	GND	XTALO	COL[0]	COL[1]	COL[2]	N	
M	AD[7]	DA[14]	AD[6]	AD[5]	CVDD			GND	GND	GND	GND	GND	GND		GND	GND	COL[4]	COL[3]	COL[6]	CSN[0]	M	
L	DA[18]	DA[17]	DA[16]	DA[15]	GND			GND	GND	GND	GND	GND	GND			CVDD	COL[5]	COL[7]	RSTON	PRSTN	L	
K	AD[22]	DA[20]	AD[21]	DA[19]	RVDD			GND	GND	GND	GND	GND	GND			CVDD	SYM	SYP	SXM	SXP	K	
J	DA[21]	DQMN[0]	DQMN[1]	DQMN[2]	GND			GND	GND	GND	GND	GND	GND			CVDD	RTCXTALI	XM	YP	YM	J	
H	DQMN[3]	CASN	RASN	SDCSN[2]	CVDD			GND	GND	GND	GND	GND	GND			RVDD	RTCXTALO	ADC_VDD	ADC_GND	XP	H	
G	SDCSN[0]	SDCSN[1]	SDWEN	SDCLK	RVDD	RVD										RVDD	RVDD	EGPIO[7]	EGPIO[9]	EGPIO[10]	EGPIO[11]	G
F	SDCSN[3]	DA[22]	DA[24]	AD[25]	RVDD	GND	CVD							CVDD	GND	GND	EGPIO[2]	EGPIO[4]	EGPIO[6]	EGPIO[8]	F	
E	AD[23]	DA[23]	DA[26]	CSN[6]	GND	GND	CVD	CVD	RVDD	GND	GND	RVDD	CVDD	CVDD	GND	ASDI	DIOWN	EGPIO[0]	EGPIO[3]	EGPIO[5]	E	
D	AD[24]	DA[25]	DD[11]	SDCLKEN	AD[19]	DD[9]	DD[5]	AD[16]	MIIRXD[2]	MIITXD[3]	TXEN	MCWAI	MCDANN	MCAENN	EGPIO[14]	WP	USBM[2]	ARSTN	DIORN	EGPIO[1]	D	
C	CSN[1]	CSN[3]	AD[20]	DA[29]	DD[10]	DD[6]	DD[2]	MDC	MIIRXD[3]	TXCLK	MIITXD[0]	READY	MCD2	MCDIR	MCELN	IORDN	MCWRN	USBP[2]	IORDY	DMACKN	C	
B	CSN[2]	DA[31]	DA[30]	DA[27]	DD[7]	DD[3]	WRN	MDIO	MIIRXD[1]	RXERR	MIITXD[1]	CRS	VS1	MCD1	MCBVD2	MCEHN	EGPIO[13]	MCRDN	WAITN	TRSTN	B	
A	CSN[7]	DA[28]	AD[18]	DD[8]	DD[4]	AD[17]	RDN	RXCLK	MIIRXD[0]	RXDVAL	MIITXD[2]	TXERR	CLD	VS2	MCBVD1	MCREGN	EGPIO[12]	EGPIO[15]	IOWRN	MCRESTN	A	
	1	2	3	4	5	6	7	8	9	10	11	12	13	14	15	16	17	18	19	20		

Pin List

The following Plastic Ball Grid Array (PBGA) ball assignment table is sorted in order of ball.

Ball	Signal	Ball	Signal	Ball	Signal	Ball	Signal
A1	CSN[7]	E9	RVDD	L3	DA[16]	T13	CVDD
A2	DA[28]	E10	GND	L4	DA[15]	T14	GND
A3	AD[18]	E11	GND	L5	GND	T15	INT[0]
A4	DD[8]	E12	RVDD	L8	GND	T16	USBM[1]
A5	DD[4]	E13	CVDD	L9	GND	T17	RXD[0]
A6	AD[17]	E14	CVDD	L10	GND	T18	TXD[2]
A7	RDN	E15	GND	L11	GND	T19	ROW[2]
A8	RXCLK	E16	ASDI	L12	GND	T20	ROW[4]
A9	MIIRXD[0]	E17	DIOWN	L13	GND	U1	AD[0]
A10	RXDVAL	E18	EGPIO[0]	L16	CVDD	U2	P[15]
A11	MIITXD[2]	E19	EGPIO[3]	L17	COL[5]	U3	P[10]
A12	TXERR	E20	EGPIO[5]	L18	COL[7]	U4	P[7]
A13	CLD	F1	SDCSN[3]	L19	RSTON	U5	P[6]
A14	VS2	F2	DA[22]	L20	PRSTN	U6	P[4]
A15	MCBVD1	F3	DA[24]	M1	AD[7]	U7	P[0]
A16	MCREGN	F4	AD[25]	M2	DA[14]	U8	AD[13]
A17	EGPIO[12]	F5	RVDD	M3	AD[6]	U9	DA[3]
A18	EGPIO[15]	F6	GND	M4	AD[5]	U10	DA[0]
A19	IOWRN	F7	CVDD	M5	CVDD	U11	DSRN
A20	MCRESETN	F14	CVDD	M8	GND	U12	BOOT[1]
B1	CSN[2]	F15	GND	M9	GND	U13	NC
B2	DA[31]	F16	GND	M10	GND	U14	SSPRX1
B3	DA[30]	F17	EGPIO[2]	M11	GND	U15	INT[1]
B4	DA[27]	F18	EGPIO[4]	M12	GND	U16	PWMOUT
B5	DD[7]	F19	EGPIO[6]	M13	GND	U17	USBM[0]
B6	DD[3]	F20	EGPIO[8]	M16	GND	U18	RXD[1]
B7	WRN	G1	SDCSN[0]	M17	COL[4]	U19	TXD[1]
B8	MDIO	G2	SDCSN[1]	M18	COL[3]	U20	ROW[1]
B9	MIIRXD[1]	G3	SDWEN	M19	COL[6]	V1	P[16]
B10	RXERR	G4	SDCLK	M20	CSN[0]	V2	P[11]
B11	MIITXD[1]	G5	RVDD	N1	DA[13]	V3	P[8]
B12	CRS	G6	RVDD	N2	DA[12]	V4	DD[15]
B13	VS1	G15	RVDD	N3	DA[11]	V5	DD[13]
B14	MCD1	G16	RVDD	N4	AD[3]	V6	P[1]
B15	MCBVD2	G17	EGPIO[7]	N5	CVDD	V7	AD[14]
B16	MCEHN	G18	EGPIO[9]	N6	CVDD	V8	AD[12]
B17	EGPIO[13]	G19	EGPIO[10]	N8	GND	V9	DA[2]
B18	MCRDN	G20	EGPIO[11]	N9	GND	V10	IDECS0N
B19	WAITN	H1	DQMN[3]	N10	GND	V11	IDEDA[2]
B20	TRSTN	H2	CASN	N11	GND	V12	TDI
C1	CSN[1]	H3	RASN	N12	GND	V13	GND
C2	CSN[3]	H4	SDCSN[2]	N13	GND	V14	ASYNC

Ball	Signal	Ball	Signal	Ball	Signal	Ball	Signal
C3	AD[20]	H5	CVDD	N15	GND	V15	SSPTX1
C4	DA[29]	H8	GND	N16	GND	V16	INT[2]
C5	DD[10]	H9	GND	N17	XTALO	V17	RTSN
C6	DD[6]	H10	GND	N18	COL[0]	V18	USBP[0]
C7	DD[2]	H11	GND	N19	COL[1]	V19	CTSN
C8	MDC	H12	GND	N20	COL[2]	V20	TXD[0]
C9	MIIRXD[3]	H13	GND	P1	AD[4]	W1	P[12]
C10	TXCLK	H16	RVDD	P2	DA[10]	W2	P[9]
C11	MIITXD[0]	H17	RTCXTALO	P3	DA[9]	W3	DD[0]
C12	READY	H18	ADC_VDD	P4	BRIGHT	W4	P[5]
C13	MCD2	H19	ADC_GND	P5	RVDD	W5	P[3]
C14	MCDIR	H20	XP	P6	RVDD	W6	DA[7]
C15	MCELN	J1	DA[21]	P15	RVDD	W7	DA[5]
C16	IORDN	J2	DQMN[0]	P16	RVDD	W8	AD[11]
C17	MCWRN	J3	DQMN[1]	P17	XTALI	W9	AD[9]
C18	USBP[2]	J4	DQMN[2]	P18	PLL_VDD	W10	IDECS1N
C19	IORDY	J5	GND	P19	ROW[6]	W11	IDEDA[1]
C20	DMACKN	J8	GND	P20	ROW[7]	W12	TCK
D1	AD[24]	J9	GND	R1	AD[2]	W13	TMS
D2	DA[25]	J10	GND	R2	AD[1]	W14	EECLK
D3	DD[11]	J11	GND	R3	P[17]	W15	SCLK1
D4	SDCLKEN	J12	GND	R4	P[14]	W16	GRLED
D5	AD[19]	J13	GND	R5	RVDD	W17	INT[3]
D6	DD[9]	J16	CVDD	R6	RVDD	W18	SLA[1]
D7	DD[5]	J17	RTCXTALI	R7	GND	W19	SLA[0]
D8	AD[16]	J18	XM	R8	CVDD	W20	RXD[2]
D9	MIIRXD[2]	J19	YP	R13	CVDD	Y1	HSYNC
D10	MIITXD[3]	J20	YM	R14	GND	Y2	DD[1]
D11	TXEN	K1	AD[22]	R15	RVDD	Y3	DD[12]
D12	MCWAITN	K2	DA[20]	R16	RVDD	Y4	P[2]
D13	MCD AENN	K3	AD[21]	R17	ROW[0]	Y5	AD[15]
D14	MCAENN	K4	DA[19]	R18	ROW[3]	Y6	DA[6]
D15	EGPIO[14]	K5	RVDD	R19	PLL_GND	Y7	DA[4]
D16	WP	K8	GND	R20	ROW[5]	Y8	AD[10]
D17	USBM[2]	K9	GND	T1	DA[8]	Y9	DA[1]
D18	ARSTN	K10	GND	T2	BLANK	Y10	AD[8]
D19	DIORN	K11	GND	T3	P[13]	Y11	IDEDA[0]
D20	EGPIO[1]	K12	GND	T4	SPCLK	Y12	DTRN
E1	AD[23]	K13	GND	T5	V_CS YNC	Y13	TDO
E2	DA[23]	K16	CVDD	T6	DD[14]	Y14	BOOT[0]
E3	DA[26]	K17	SYM	T7	GND	Y15	EEDAT
E4	CSN[6]	K18	SYP	T8	CVDD	Y16	ASDO
E5	GND	K19	SXM	T9	RVDD	Y17	SFRM1
E6	GND	K20	SXP	T10	GND	Y18	RDLED
E7	CVDD	L1	DA[18]	T11	GND	Y19	USBP[1]
E8	CVDD	L2	DA[17]	T12	RVDD	Y20	ABITCLK

The following section focuses on the EP9315 pin signals from two viewpoints - the pin usage and pad characteristics, and the pin multiplexing usage. The first table (Table S) is a summary of all the EP9315 pin signals. The second table (Table T) illustrates the pin signal multiplexing and configuration options.

Table S is a summary of the EP9315 pin signals, which illustrates the pad type and pad pull type (if any). The symbols used in the table are defined as follows. (Note: A blank box means Not Applicable (NA) or, for Pull Type, No Pull (NP).)

Under the Pad Type column:

- A - Analog pad

- P - Power pad
- G - Ground pad
- I - Pin is an input only
- I/O - Pin is input/output
- 4mA - Pin is a 4 mA output driver
- 8mA - Pin is an 8 mA output driver
- 12mA - Pin is an 12 mA output driver

See the text description for additional information about bi-directional pins.

Under the Pull Type Column:

- PU - Resistor is a pull up to the RVDD supply
- PD - Resistor is a pull down to the RGND supply

Table S. Pin Descriptions

Pin Name	Block	Pad Type	Pull Type	Description
TCK	JTAG	I	PD	JTAG clock in
TDI	JTAG	I	PD	JTAG data in
TDO	JTAG	4ma		JTAG data out
TMS	JTAG	I	PD	JTAG test mode select
TRSTn	JTAG	I	PD	JTAG reset
BOOT[1:0]	System	I	PD	Boot mode select in
XTALI	PLL	A		Main oscillator input
XTALO	PLL	A		Main oscillator output
VDD_PLL	PLL	P		Main oscillator power, 1.8V
GND_PLL	PLL	G		Main oscillator ground
RTCXTALI	RTC	A		RTC oscillator input
RTCXTALO	RTC	A		RTC oscillator output
WRn	PBUS	4ma		SRAM Write strobe out
RDn	PBUS	4ma		SRAM Read / OE strobe out
WAITn	PBUS	I	PU	SRAM Wait in
AD[25:0]	PBUS	8ma		Shared Address bus out
DA[31:0]	PBUS	8ma	PU	Shared Data bus in/out
CSn[3:0]	PBUS	4ma	PU	Chip select out
CSn[7:6]	PBUS	4ma	PU	Chip select out
DQMn[3:0]	PBUS	8ma		Shared data mask out
SDCLK	SDRAM	8ma		SDRAM clock out
SDCLKEN	SDRAM	8ma		SDRAM clock enable out
SDCSn[3:0]	SDRAM	4ma		SDRAM chip selects out
RASn	SDRAM	8ma		SDRAM RAS out
CASn	SDRAM	8ma		SDRAM CAS out
SDWEn	SDRAM	8ma		SDRAM write enable out
P[17:0]	Raster	4ma	PU	Pixel data bus out
SPCLK	Raster	12ma	PU	Pixel clock in/out
HSYNC	Raster	8ma	PU	Horizontal synchronization / line pulse out

Table S. Pin Descriptions (Continued)

Pin Name	Block	Pad Type	Pull Type	Description
V_CS SYNC	Raster	8ma	PU	Vertical or composite synchronization / frame pulse out
BLANK	Raster	8ma	PU	Composite blanking signal out
BRIGHT	Raster	4ma		PWM brightness control out
PWMOUT	PWM	8ma		Pulse width modulator output
Xp, Xm	ADC	A		Touchscreen ADC X axis
Yp, Ym	ADC	A		Touchscreen ADC Y axis
sXp, sXm	ADC	A		Touchscreen ADC X axis feedback
sYp, sYm	ADC	A		Touchscreen ADC Y axis feedback
VDD_ADC	ADC	P		Touchscreen ADC power, 3.3V
GND_ADC	ADC	G		Touchscreen ADC ground
COL[7:0]	Key	8ma	PU	Key matrix column inputs
ROW[7:0]	Key	8ma	PU	Key matrix row outputs
USBp[2:0]	USB	A		USB positive signals
USBm[2:0]	USB	A		USB negative signals
TXD0	UART1	4ma		Transmit out
RXD0	UART1	I	PU	Receive in
CTS n	UART1	I	PU	Clear to send / transmit enable
DSR n	UART1	I	PU	Data set ready / Data Carrier Detect
DTR n	UART1	4ma		Data Terminal Ready output
RTS n	UART1	4ma		Ready to send
TXD1	UART2	4ma		Transmit / IrDA output
RXD1	UART2	I	PU	Receive / IrDA input
TXD2	UART3	4ma		Transmit
RXD2	UART3	I	PU	Receive
MDC	EMAC	4ma		Management data clock
MDIO	EMAC	4ma	PU	Management data input/output
RXCLK	EMAC	I	PD	Receive clock in
MIIRXD[3:0]	EMAC	I	PD	Receive data in
RXDVAL	EMAC	I	PD	Receive data valid

Table S. Pin Descriptions (Continued)

Pin Name	Block	Pad Type	Pull Type	Description
RXERR	EMAC	I	PD	Receive data error
TXCLK	EMAC	4ma	PU	Transmit clock in
MIITXD[3:0]	EMAC	I	PD	Transmit data out
TXEN	EMAC	4ma	PD	Transmit enable
TXERR	EMAC	4ma	PD	Transmit error
CRS	EMAC	I	PD	Carrier sense
CLD	EMAC	I	PU	Collision detect
GRLED	LED	12ma		Green LED
RDLED	LED	12ma		Red LED
EECLK	EEPROM	4ma	PU	EEPROM / Two-wire Interface clock
EEDAT	EEPROM	4ma	PU	EEPROM / Two-wire Interface data
ABITCLK	AC97	8ma	PD	AC97 bit clock
ASYNC	AC97	8ma	PD	AC97 frame sync
ASDI	AC97	I	PD	AC97 Primary input
ASDO	AC97	8ma	PU	AC97 output
ARSTn	AC97	8ma		AC97 reset
SCLK1	SPI1	8ma	PD	SPI bit clock
SFRM1	SPI1	8ma	PD	SPI Frame Clock
SSPRX1	SPI1	I	PD	SPI input
SSPTX1	SPI1	8ma		SPI output
INT[3:0]	INT	I	PD	External interrupts
PRSTn	Syscon	I	PU	Power on reset
RSTOn	Syscon	4ma		User Reset in out - open drain
SLA[1:0]	EEPROM	4ma		Flash programming voltage control
VS1	PCMCIA	I	PU	Voltage sense
VS2	PCMCIA	I	PU	Voltage sense
MCD1	PCMCIA	I	PU	Card detect
MCD2	PCMCIA	I	PU	Card detect
MCBVD1	PCMCIA	I	PU	Voltage detection / status change
MCBVD2	PCMCIA	I	PU	Voltage detection
MCDIR	PCMCIA	4ma		Data transceiver direction control
MCDAENn	PCMCIA	4ma		Data bus transceiver enable
MCADENn	PCMCIA	4ma		Address bus transceiver enable
MCREGn	PCMCIA	4ma	PU	Memory card register
MCEHn	PCMCIA	4ma	PU	Memory card high byte select
MCELn	PCMCIA	4ma	PU	Memory card low byte select
IORDn	PCMCIA	4ma	PU	I/O card read
IOWRn	PCMCIA	4ma	PU	I/O card write
MCRDn	PCMCIA	4ma	PU	Memory card read
MCWRn	PCMCIA	4ma	PU	Memory card write
READY	PCMCIA	I	PU	Ready / interrupt
WP	PCMCIA	I	PU	Write protect
MCWAITn	PCMCIA	I	PU	Wait Input
MCRESETn	PCMCIA	4ma		Card reset
EGPIO[15:0]	GPIO	I/O, 4 ma	PU	Enhanced GPIO
DD[15:0]	IDE	8ma	PU	IDE data bus
IDEDA[2:0]	IDE	8ma		IDE Device address output
IDECS0n	IDE	8ma		IDE Chip Select 0 output

Table S. Pin Descriptions (Continued)

Pin Name	Block	Pad Type	Pull Type	Description
IDECS1n	IDE	8ma		IDE Chip Select 1 output
DIORn	IDE	8ma		IDE Read strobe output
DIOWn	IDE	8ma		IDE Write strobe output
DMACKn	IDE	8ma		IDE DMA acknowledge output
IORDY	IDE	I	PU	IDE ready input
CVDD	Power	P		Digital power, 1.8V
RVDD	Power	P		Digital power, 3.3V
CGND	Ground	G		Digital ground
RGND	Ground	G		Digital ground

Table T illustrates the pin signal multiplexing and configuration options.

Table T. Pin Multiplex Usage Information

Physical Pin Name	Description	Multiplex signal name
COL[7:0]	GPIO	GPIO Port D[7:0]
ROW[7:0]	GPIO	GPIO Port C[7:0]
EGPIO[0]	Ring Indicator Input	RI
EGPIO[1]	1Hz clock monitor	CLK1HZ
EGPIO[2]	IDE DMA request	DMARQ
EGPIO[3]	Transmit Enable output / HDLC clocks	TENn / HDLCCLK1 / HDLCCLK3
EGPIO[4]	I2S Transmit Data 1	SDO1
EGPIO[5]	I2S Receive Data 1	SDI1
EGPIO[6]	I2S Transmit Data 2	SDO2
EGPIO[7]	DMA Request 0	DREQ0
EGPIO[8]	DMA Acknowledge 0	DACK0
EGPIO[9]	DMA EOT 0	DEOT0
EGPIO[10]	DMA Request 1	DREQ1
EGPIO[11]	DMA Acknowledge 1	DACK1
EGPIO[12]	DMA EOT 1	DEOT1
EGPIO[13]	I2S Receive Data 2	SDI2
EGPIO[14]	PWM 1 output	PWMOUT1
EGPIO[15]	IDE Device active / present	DASP
ABITCLK	I2S Serial clock	SCLK
ASYNC	I2S Frame Clock	LRCK
ASDO	I2S Transmit Data 0	SDO0
ASDI	I2S Receive Data 0	SDI0
ARSTn	I2S Master clock	MCLK
SCLK1	I2S Serial clock	SCLK
SFRM1	I2S Frame Clock	LRCK
SSPTX1	I2S Transmit Data 0	SDO0
SSPRX1	I2S Receive Data 0	SDI0
IDEDA[2:0]	GPIO	GPIO Port E[7:5]
IDECS0n	GPIO	GPIO Port E[4]
IDECS1n	GPIO	GPIO Port E[3]
DIORn	GPIO	GPIO Port E[2]
DD[7:0]	GPIO	GPIO Port H[7:0]
DD[15:12]	GPIO	GPIO Port G[7:4]

Acronyms and Abbreviations

The following tables list abbreviations and acronyms used in this data sheet.

Term	Definition
ADC	Analog-to-Digital Converter
ALT	Alternative
AMBA	Advanced Micro-controller Bus Architecture
ATAPI	ATA Packet Interface
CODEC	COder / DECoder
CRC	Cyclic Redundancy Check
DAC	Digital-to-Analog Converter
DMA	Direct-Memory Access
EEPROM	Electrically Erasable Programmable Read Only Memory
EMAC	Ethernet Media Access Controller
FIFO	First In / First Out
FIQ	Fast Interrupt Request
FLASH	Flash memory
GPIO	General Purpose I/O
HDLC	High-level Data Link Control
I/F	Interface
I ² S	Inter-IC Sound
IC	Integrated Circuit
ICE	In-Circuit Emulator
IDE	Integrated Drive Electronics
IEEE	Institute of Electronics and Electrical Engineers
IrDA	Infrared Data Association
IRQ	Standard Interrupt Request
ISO	International Standards Organization
JTAG	Joint Test Action Group
LFSR	Linear Feedback Shift Register
MII	Media Independent Interface
MMU	Memory Management Unit
OHCI	Open Host Controller Interface

Term	Definition
PHY	Ethernet PHYSical layer interface
PIO	Programmed I/O
RISC	Reduced Instruction Set Computer
SDMI	Secure Digital Music Initiative
SDRAM	Synchronous Dynamic RAM
SPI	Serial Peripheral Interface
SRAM	Static Random Access Memory
STA	Station - Any device that contains an IEEE 802.11 conforming Medium Access Control (MAC) and physical layer (PHY) interface to the wireless medium
TFT	Thin Film Transistor
TLB	Translation Lookaside Buffer
USB	Universal Serial Bus

Units of Measurement

Symbol	Unit of Measure
°C	degree Celsius
Hz	Hertz = cycle per second
Kbps	Kilobits per second
Kbyte	Kilobyte
KHz	KiloHertz = 1000 Hz
Mbps	Megabits per second
MHz	MegaHertz = 1,000 KiloHertz
μA	microAmpere = 10 ⁻⁶ Ampere
μs	microsecond = 1,000 nanoseconds = 10 ⁻⁶ seconds
mA	milliAmpere = 10 ⁻³ Ampere
ms	millisecond = 1,000 microseconds = 10 ⁻³ seconds
mW	milliWatt = 10 ⁻³ Watts
ns	nanosecond = 10 ⁻⁹ seconds
pF	picoFarad = 10 ⁻¹² Farads
V	Volt
W	Watt

ORDERING INFORMATION

The order numbers for the device are:

EP9315-CB	0°C to +70°C	352-pin PBGA	
EP9315-CBZ	0°C to +70°C	352-pin PBGA	Lead Free
EP9315-IB	-40°C to +85°C	352-pin PBGA	
EP9315-IBZ	-40°C to +85°C	352-pin PBGA	Lead Free

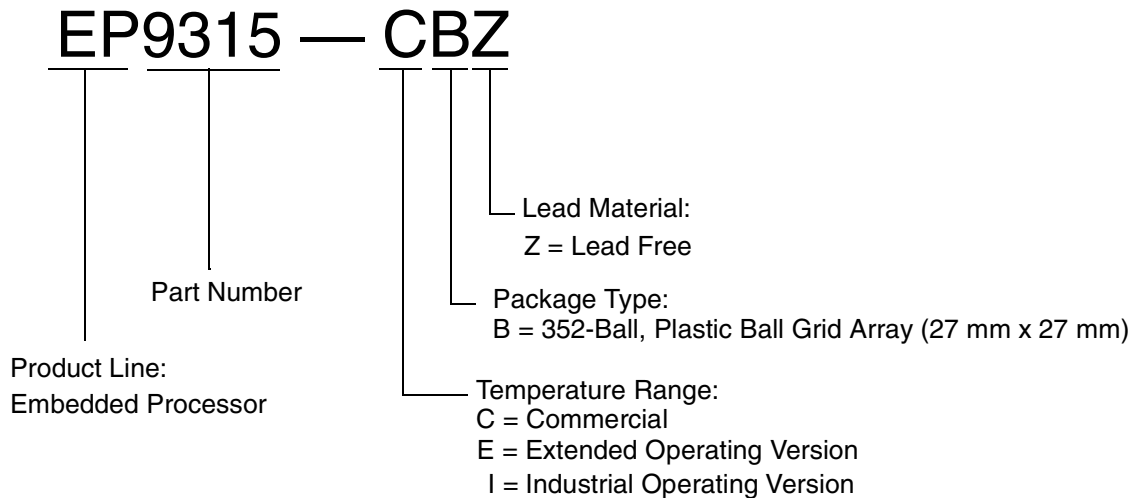

Note: Go to the Cirrus Logic Internet site at <http://www.cirrus.com> to find contact information for your local sales representative.

Contacting Cirrus Logic Support

For all product questions and inquiries contact a Cirrus Logic Sales Representative.
To find one nearest you go to www.cirrus.com

IMPORTANT NOTICE

"Preliminary" product information describes products that are in production, but for which full characterization data is not yet available. Cirrus Logic, Inc. and its subsidiaries ("Cirrus") believe that the information contained in this document is accurate and reliable. However, the information is subject to change without notice and is provided "AS IS" without warranty of any kind (express or implied). Customers are advised to obtain the latest version of relevant information to verify, before placing orders, that information being relied on is current and complete. All products are sold subject to the terms and conditions of sale supplied at the time of order acknowledgment, including those pertaining to warranty, patent infringement, and limitation of liability. No responsibility is assumed by Cirrus for the use of this information, including use of this information as the basis for manufacture or sale of any items, or for infringement of patents or other rights of third parties. This document is the property of Cirrus and by furnishing this information, Cirrus grants no license, express or implied under any patents, mask work rights, copyrights, trademarks, trade secrets or other intellectual property rights. Cirrus owns the copyrights associated with the information contained herein and gives consent for copies to be made of the information only for use within your organization with respect to Cirrus integrated circuits or other products of Cirrus. This consent does not extend to other copying such as copying for general distribution, advertising or promotional purposes, or for creating any work for resale.

CERTAIN APPLICATIONS USING SEMICONDUCTOR PRODUCTS MAY INVOLVE POTENTIAL RISKS OF DEATH, PERSONAL INJURY, OR SEVERE PROPERTY OR ENVIRONMENTAL DAMAGE ("CRITICAL APPLICATIONS"). CIRRUS PRODUCTS ARE NOT DESIGNED, AUTHORIZED OR WARRANTED FOR USE IN AIRCRAFT SYSTEMS, MILITARY APPLICATIONS, PRODUCTS SURGICALLY IMPLANTED INTO THE BODY, LIFE SUPPORT PRODUCTS OR OTHER CRITICAL APPLICATIONS (INCLUDING MEDICAL DEVICES, AIRCRAFT SYSTEMS OR COMPONENTS AND PERSONAL OR AUTOMOTIVE SAFETY OR SECURITY DEVICES). INCLUSION OF CIRRUS PRODUCTS IN SUCH APPLICATIONS IS UNDERSTOOD TO BE FULLY AT THE CUSTOMER'S RISK AND CIRRUS DISCLAIMS AND MAKES NO WARRANTY, EXPRESS, STATUTORY OR IMPLIED, INCLUDING THE IMPLIED WARRANTIES OF MERCHANTABILITY AND FITNESS FOR PARTICULAR PURPOSE, WITH REGARD TO ANY CIRRUS PRODUCT THAT IS USED IN SUCH A MANNER. IF THE CUSTOMER OR CUSTOMER'S CUSTOMER USES OR PERMITS THE USE OF CIRRUS PRODUCTS IN CRITICAL APPLICATIONS, CUSTOMER AGREES, BY SUCH USE, TO FULLY INDEMNIFY CIRRUS, ITS OFFICERS, DIRECTORS, EMPLOYEES, DISTRIBUTORS AND OTHER AGENTS FROM ANY AND ALL LIABILITY, INCLUDING ATTORNEYS' FEES AND COSTS, THAT MAY RESULT FROM OR ARISE IN CONNECTION WITH THESE USES.

Cirrus Logic, Cirrus, MaverickCrunch, MaverickKey, and the Cirrus Logic logo designs are trademarks of Cirrus Logic, Inc. All other brand and product names in this document may be trademarks or service marks of their respective owners.

Microsoft and Windows are registered trademarks of Microsoft Corporation.

Microwire is a trademark of National Semiconductor Corp. National Semiconductor is a registered trademark of National Semiconductor Corp.

Texas Instruments is a registered trademark of Texas Instruments, Inc.

Motorola is a registered trademark of Motorola, Inc.

LINUX is a registered trademark of Linus Torvalds.

