

Armadillo-420 Basic Model Development Set Startup Guide

A4200-D00Z

**Version 1.0.1
2010/11/05**

Atmark Techno, Inc.

Armadillo Developers Site

Armadillo-420 Basic Model Development Set Startup Guide

Atmark Techno, Inc.

060-0035 AFT Bldg. 6F, N5E2, Chuo-ku, Sapporo
TEL 011-207-6550 FAX 011-207-6570

© 2010 Atmark Techno, Inc.

Version 1.0.1
2010/11/05

1. Preface	8
1.1. Who Should Read This Document	8
1.2. Document Structure	8
1.3. Typographical Conventions	8
1.3.1. Fonts	8
1.3.2. Command Entry Examples	9
1.3.3. Icons	9
1.4. Acknowledgements	9
1.5. Safety Precautions	10
1.6. Handling Precautions	10
1.7. Software Usage Precautions	10
1.8. Trademarks	11
2. Before Getting Started	12
2.1. Layout Diagram	12
2.2. Preparation	13
2.3. Connections	13
2.3.1. microSD Insertion	13
2.4. Jumper Pin Configuration	14
2.5. Serial Console Software Configuration	14
3. Startup and Shutdown	15
3.1. Startup	15
3.2. Login	18
3.3. Shutdown Method	18
4. Network	20
4.1. Default Network Connection Mechanisms	20
4.1.1. DHCP Connections	20
4.1.2. Zeroconf Connections	20
4.2. Changing Network Configuration	20
4.2.1. Using a Web Browser to Change Network Configuration	21
4.2.2. Logging In to Change Network Configuration	21
4.2.3. Checking The Connection	22
4.3. Firewall	22
4.4. Network Applications	22
4.4.1. Telnet	22
4.4.2. FTP	23
4.4.3. SSH	23
4.4.4. Web Server	24
4.4.5. NTP Client	24
4.4.6. SMTP Client	24
4.4.7. at-cgi	25
4.5. Using Bonjour	39
4.5.1. Installing Bonjour	39
4.5.2. Operational Check	41
4.5.3. Bonjour Hostnames	42
5. Storage	43
5.1. Devices Which Can Be Used As Storage	43
5.2. Storage Initialization and Mounting	43
5.2.1. Disk Initialization	43
5.2.2. Filesystem Creation	44
5.2.3. Mounting	44
5.3. Storage Operational Check	44
5.3.1. Writing Data	44
5.3.2. Checking Data	45

6. Input Devices	46
6.1. evtest	46
6.2. swmgr	46
6.3. swmgr Example	47
7. Other Devices	48
7.1. LED	48
7.1.1. Activating and Deactivating LEDs	48
7.1.2. Using Triggers	48
7.2. GPIO	49
7.2.1. Changing I/O Direction	50
7.2.2. Obtaining Input Level	50
7.2.3. Configuring Output Level	50
7.3. RTC	50
7.3.1. Setting System Clock With date	51
7.3.2. Setting System Clock With NTP Client	51
7.3.3. Setting Hardware Clock	51
7.4. UVC Compatible Web Cameras	51
8. Boot Modes and Bootloader Functions	53
8.1. Boot Mode Selection	53
8.2. Linux Kernel Boot Option Configuration	53
8.2.1. Console Configuration	53
8.2.2. Specifying Image File To Boot	54
8.2.3. Other Boot Options	54
8.2.4. Boot Option Configuration Examples	54
9. Config Region - Configuration File Storage	55
9.1. Reading From The Config Region	55
9.2. Saving To The Config Region	55
9.3. Initializing The Config Region	55
10. Troubleshooting	56
10.1. The Armadillo Will Not Boot	56
10.2. The Armadillo Cannot Be Found With Bonjour	56
10.3. The Screen Does Not Display After Changing The Network Configuration	56

2.1. Layout Diagram	12
2.2. Connection Diagram	13
2.3. microSD Insertion Diagram	14
3.1. Boot Log	15
3.2. Shutdown Method	18
4.1. Static IP Address Configuration	21
4.2. DHCP Configuration	21
4.3. DNS Server Configuration	21
4.4. Enabling Configuration	22
4.5. Ping Confirmation	22
4.6. iptables	22
4.7. telnet	22
4.8. ftp	23
4.9. Starting sshd	23
4.10. ssh	23
4.11. ntpclient	24
4.12. mail	24
4.13. Hostname Configuration Confirmation	24
4.14. AT Admin: Overview	25
4.15. AT Admin: System Username / Password Authorization	26
4.16. AT Admin: System - System Overview	28
4.17. AT Admin: System - Network	30
4.18. AT Admin: System - Network Update	32
4.19. AT Admin: System - Password	33
4.20. AT Admin: System - Firmware	34
4.21. AT Admin: System - Updating Firmware	36
4.22. AT Admin: System - Save & Load	37
4.23. AT Admin: System - Reload	38
4.24. AT Admin: System - Reboot	39
4.25. Internet Explorer Explorer Bar Configuration	41
4.26. "Bonjour" Explorer Bar	41
4.27. Web Server Top Page	42
5.1. Disk Initialization Method	43
5.2. Filesystem Creation	44
5.3. Mount Method	44
5.4. Writing Data To Storage	45
5.5. Writing Data To Storage	45
5.6. Storage Data Check	45
6.1. evtest Command Format	46
6.2. swmgr Command Format	46
6.3. swmgr Example 1	47
7.1. Turning LED5 On	48
7.2. Turning LED5 Off	48
7.3. Displaying LED5 State	48
7.4. Specifying timer As Trigger For LED3	49
7.5. Displaying LED3 Timer	49
7.6. Obtaining CON9_1 Input Level	50
7.7. Configuring CON9_2 Output Level	50
7.8. MJPG-Streamer Demo Page	52
8.1. Linux Kernel Boot Option Clear	53
8.2. Console Designation	53
8.3. Boot Option Configuration Example 1	54
9.1. Reading From The Config Region	55

9.2. Saving To The Config Region 55
9.3. Config Region Initialization 55

- 1.1. Fonts 9
- 1.2. Relationship Between Prompt and Execution Environment 9
- 1.3. Abbreviations Used In Command Entry Examples 9
- 2.1. Serial Communication Configuration 14
- 3.1. Serial Console Login Username and Password 18
- 4.1. Static IP Address Configuration Example 21
- 4.2. Username for Telnet Login 22
- 4.3. Username for FTP Login 23
- 4.4. Username for ssh Login 23
- 4.5. Armadillo-420 Bonjour Links 41
- 5.1. Storage Devices 43
- 6.1. Input Device Files 46
- 6.2. Buttons Supported By swmgr 46
- 7.1. LEDs and LED Class Directories 48
- 7.2. trigger Configuration 49
- 7.3. GPIO and GPIO Class Directories 49
- 7.4. direction Configuration 50
- 8.1. Boot Modes 53
- 8.2. Console Configuration Effect On Output Destination 54

1. Preface

Thank you for purchasing the Armadillo-420 Basic Model Development Set.

The Armadillo-420 Basic Model is comprised of the Armadillo-420 CPU board and the Armadillo-400 RTC Option Module.

The Armadillo-420 is a small form factor general purpose CPU board which along with the Freescale ARM9 processor "i.MX257", LPDDR SDRAM and flash memory, also incorporates interfaces which are often required for embedded devices, such as serial, LAN, USB 2.0, microSD and GPIO. Armadillo-420 keeps pin compatibility with the existing Armadillo-220 model while at the same time also offering improved performance and even lower power consumption.

The Armadillo-400 RTC Option Module can be connected to Armadillo-420 or Armadillo-440 to add RTC functionality.

Linux is employed as the standard operating system on Armadillo-420, providing access to a rich array of software resources. It is also possible to create and run original programs with C and other programming languages. For information on how to customize software, please refer to the "Armadillo-400 Series Software Manual."

This document contains precautions for use and explanations on how to use the software functionality available in the default state as at time of purchase. On obtaining the Armadillo-420 Basic Model Development Set, please check the operation of all hardware and the use of the default software.

The product name "Armadillo" will be used in descriptions that apply to the whole Armadillo Series for the remainder of this document.

1.1. Who Should Read This Document

- Those undertaking a hardware operation check
- Those seeking to understand basic software use

We hope that this document will prove to be useful to others as well.

1.2. Document Structure

This document describes the basic usage of Armadillo.

The main areas covered are listed below.

- Connections
- Startup and Shutdown
- Configuration
- Application usage

1.3. Typographical Conventions

1.3.1. Fonts

Fonts are used in the following ways in this document.

1.1 Fonts

Font Example	Description
Plain text font	Used for standard text
[PC ~]\$ ls	Shell prompt and user input text
text	Text that is either displayed, is to be edited, or is a comment

1.3.2. Command Entry Examples

The command entry examples in this document all have an assumed execution environment which is reflected in the displayed prompt. The directory part “/” will differ depending on the current directory. The home directory of each user is represented by “~”.

1.2 Relationship Between Prompt and Execution Environment

Prompt	Command Execution Environment
[PC /]#	To be executed by a privileged user on the work PC
[PC /]\$	To be executed by a general user on the work PC
[armadillo /]#	To be executed by a privileged user on Armadillo
[armadillo /]\$	To be executed by a general user on Armadillo
hermit>	To be executed on Armadillo in maintenance mode

Commands that may change or vary depending on the relevant environment are written as shown below. Please adjust the commands as necessary.

1.3 Abbreviations Used In Command Entry Examples

Notation	Description
[version]	File version number

1.3.3. Icons

Icons are used in the following way in this document.



This is used for precautions.



This is used for helpful information.

1.4. Acknowledgements

The software used on Armadillo is composed from Free Software / Open Source Software. This Free Software / Open Source Software is the result of efforts from developers from all over the world. We would like to take this opportunity to express our gratitude.

1.5. Safety Precautions

In order to use this product safely, please take special note of the following precaution.



This product uses semiconductor components designed for generic electronics equipment such as office automation equipment, communications equipment, measurement equipment and machine tools. Do not incorporate the product into devices such as medical equipment, traffic control systems, combustion control systems, safety equipment and so on which can directly threaten human life or pose a hazard to the body or property due to malfunction or failure. Moreover, products incorporating semiconductor components can be caused to malfunction or fail due to foreign noise or surge. To ensure there will be no risk to life, the body or property even in the event of malfunction or failure, be sure to take all possible measures in safety system design, such as using protection circuits like limit switches or fuse breakers, or system redundancy.

1.6. Handling Precautions

Please pay attention to the following points when handling the product in order to avoid causing any irreversible damage.

Areas Easily Damaged	The microSD connector and its cover can be easily damaged. Please be careful not to damage them by handling them with too much force.
Modifications To This Product	Please take note that any modifications ^[1] made to this product are not covered under warranty. Also, please ensure to undertake a full operational check of this product before carrying out any modifications or mounting connectors ^[2] .
Mounting and Dismounting of Connectors While Powered On	Apart from hot-pluggable interfaces (LAN, USB), do not under any circumstances add or remove connectors while power is supplied to this product or peripheral circuits.
Static Electricity	As CMOS devices are used in this product, please store it in antistatic packaging (such as that it was shipped in) until time of use.
Latchup	Excessive noise or a surge from the power supply or input/output, or sharp voltage fluctuations can lead to the CMOS devices incorporated in the board causing a latch-up. Once the latch-up occurs, this situation continues until the power supply is disconnected, and therefore can damage the devices. Measures such as adding a protection circuit to noise-susceptible input/output lines or not sharing the power supply with devices that can be the cause of noise are highly recommended.
Physical Stress	Please avoid strong physical stress such as drops or other impacts.

1.7. Software Usage Precautions

About Software Contained In This Product	The software and documentation contained in this product is provided “AS IS” without warranty of any kind including warranty of merchantability or fitness for a particular purpose, reliability, correctness or accuracy. Furthermore, no guarantee is made in regard to any outcomes resulting from the use of this product.
--	--

^[1]With the exception of adding connectors to unmounted interfaces.

^[2]When mounting connectors, please ensure to apply masking, avoid solder residue coming in contact with surrounding parts and avoid creating solder balls.

1.8. Trademarks

Armadillo is a registered trademark of Atmark Techno, Inc. All other company names, product names and related trademarks are the property of their respective owners.

2. Before Getting Started

2.1. Layout Diagram

The position of each interface is shown in 2.1. Layout Diagram.

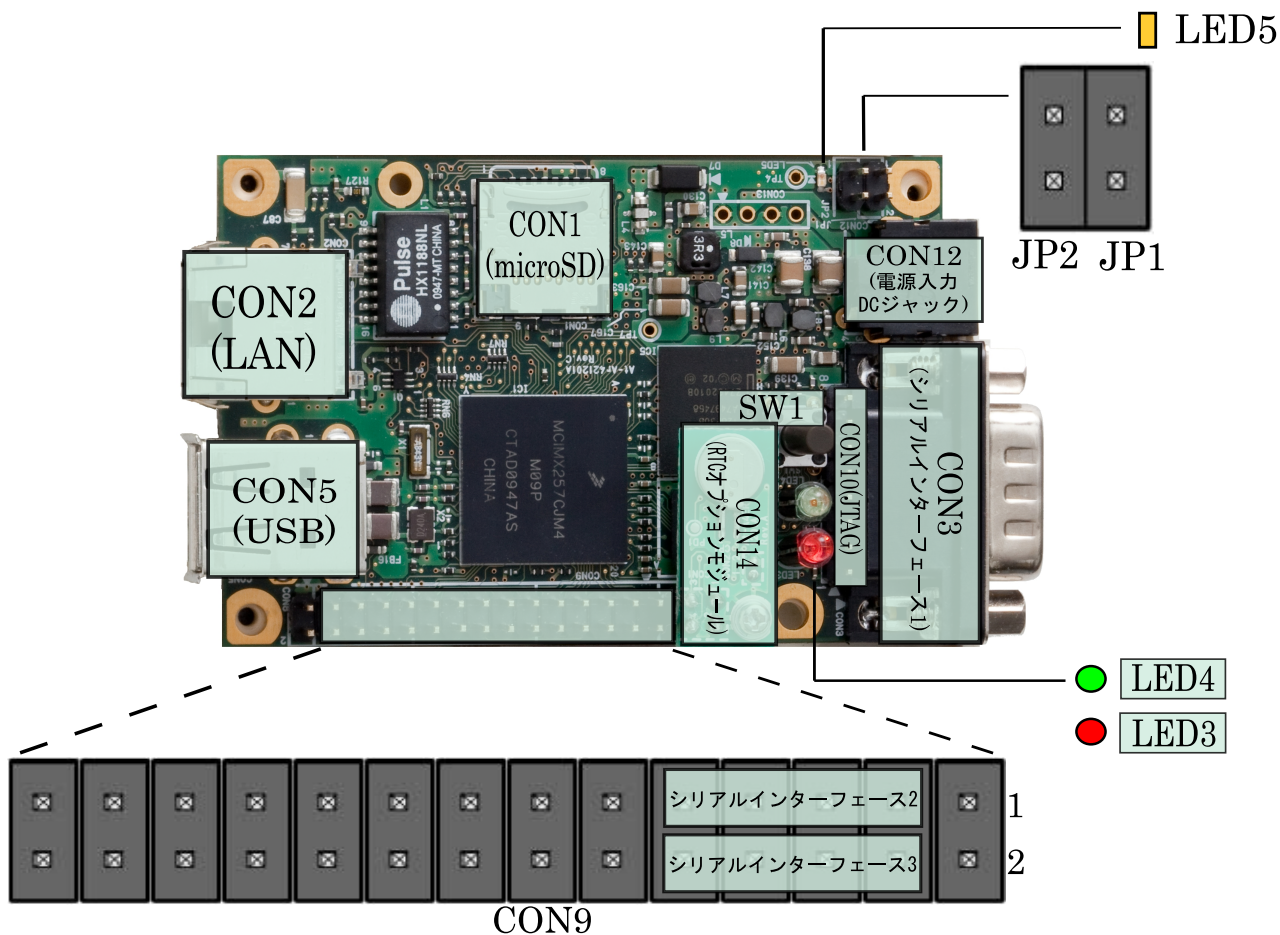

2.1 Layout Diagram



Serial Interfaces 2 and 3 have +3.3V I/O levels. They can be used at RS232C levels by connecting the RS232C level conversion adapter included in the Development Set.

When using the RS232C level conversion adapter, please connect pin 1 (the yellow or green wire) to CON9 1 for Serial Interface 2 and to CON9 2 for Serial Interface 3.

2.2. Preparation

Please prepare the following items before using the Armadillo.

- Work PC and Serial Cross Cable** A PC that runs either Linux or Windows and has at least one serial port, and a D-Sub 9 pin (female-to-female) serial cross connection cable. Please install a serial console program^[1] on the work PC (software for Linux is contained in the tool directory on the included DVD).
- Network Environment** Please connect the Armadillo and Work PC so that they can communicate via a network.

2.3. Connections

An example of the connections between the Armadillo and Work PC is shown in 2.2. Connection Diagram.

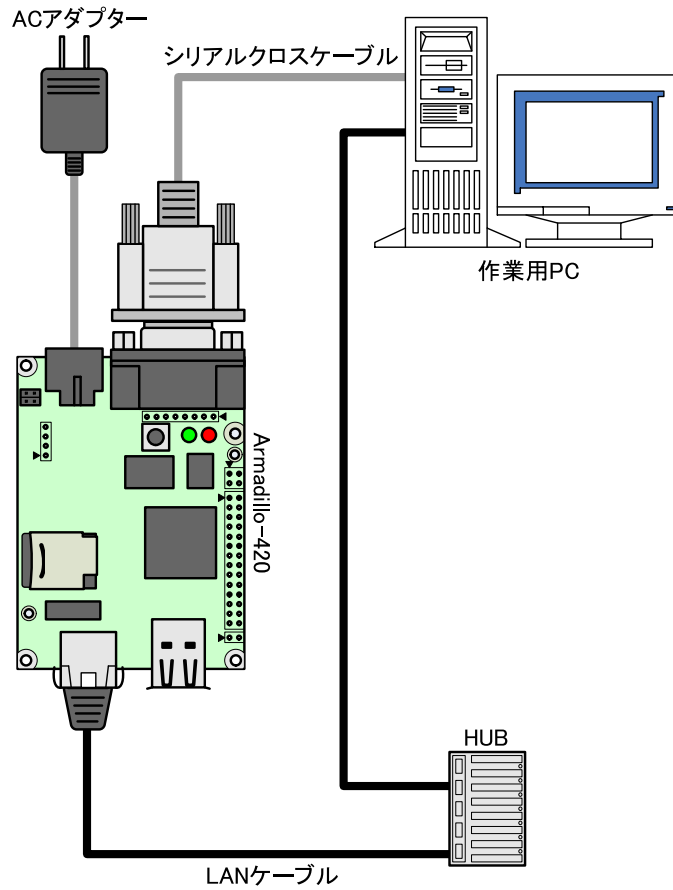

2.2 Connection Diagram

2.3.1. microSD Insertion

CON1 is a hinge type connector. The cover on the connector must be opened in order to insert and remove the card. When opening, the cover should first be unlocked by sliding the upper part of the connector horizontally in the direction shown by the OPEN arrow.

^[1]For example, "minicom" for Linux and "Tera Term" for Windows.

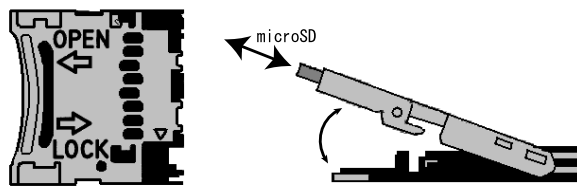

2.3 microSD Insertion Diagram



Please be aware that the connector may be damaged if excessive force is applied.

2.4. Jumper Pin Configuration

There will be no need to change jumper pins other than JP2 in this document. Please leave JP1 in an open state. It will be noted when any change to JP2 is required. Set it to an open state now.

The position of the jumper pins can be seen in 2.1. Layout Diagram.

2.5. Serial Console Software Configuration

Start the serial console program and configure the connection as shown in 2.1. Serial Communication Configuration.

2.1 Serial Communication Configuration

Item	Configuration
Transmission Rate	115,200bps
Data Length	8bit
Stop Bit	1bit
Parity	None
Flow Control	None

3. Startup and Shutdown

3.1. Startup

Connect the power supply to the Armadillo. The boot log shown below will be displayed in the serial console program.

```

Hermit-At v2.0.0 (armadillo4x0) compiled at 23:03:08, Mar 08 2010
Uncompressing
kernel.....done.
Uncompressing
ramdisk.....done.
Linux version 2.6.26-at8 (2.6.26) (atmark@atde3) (gcc version 4.3.2 (Debian
4.3.2-1.1) ) #1 PREEMPT Mon Apr 26 18:11:22 JST 2010
CPU: ARM926EJ-S [41069264] revision 4 (ARMv5TEJ), cr=00053177
Machine: Armadillo-420
Memory policy: ECC disabled, Data cache writeback
CPU0: D VIVT write-back cache
CPU0: I cache: 16384 bytes, associativity 4, 32 byte lines, 128 sets
CPU0: D cache: 16384 bytes, associativity 4, 32 byte lines, 128 sets
Built 1 zonelists in Zone order, mobility grouping on. Total pages: 16256
Kernel command line: console=ttymxc1,115200
MXC IRQ initialized
PID hash table entries: 256 (order: 8, 1024 bytes)
MXC GPT timer initialized, rate = 12000000
Console: colour dummy device 80x30
Dentry cache hash table entries: 8192 (order: 3, 32768 bytes)
Inode-cache hash table entries: 4096 (order: 2, 16384 bytes)
Memory: 64MB = 64MB total
Memory: 47892KB available (3248K code, 223K data, 128K init)
Mount-cache hash table entries: 512
CPU: Testing write buffer coherency: ok
net_namespace: 480 bytes
NET: Registered protocol family 16
MXC WDOG1 Enabled
CPU is i.MX25 Revision 1.0
Clock input source is 24000000
MXC GPIO hardware
Using SDMA I.API
MXC DMA API initialized
SCSI subsystem initialized
usbcore: registered new interface driver usbfs
usbcore: registered new interface driver hub
usbcore: registered new device driver usb
MXC I2C driver
MXC I2C driver
MXC I2C driver
MC34704 regulator successfully probed
    
```

```

mc34704 0-0054: Loaded
NET: Registered protocol family 2
IP route cache hash table entries: 1024 (order: 0, 4096 bytes)
TCP established hash table entries: 2048 (order: 2, 16384 bytes)
TCP bind hash table entries: 2048 (order: 1, 8192 bytes)
TCP: Hash tables configured (established 2048 bind 2048)
TCP reno registered
NET: Registered protocol family 1
checking if image is initramfs...it isn't (bad gzip magic numbers); looks like an
initrd
Freeing initrd memory: 13410K
usb: Host 2 host (serial) registered
usb: DR host (utmi) registered
msgmni has been set to 119
io scheduler noop registered
io scheduler cfq registered (default)
Serial: MXC Internal UART driver
mxcintuart.1: ttymxc1 at MMIO 0x43f94000 (irq = 32) is a Freescale MXC
console [ttymxc1] enabled
mxcintuart.2: ttymxc2 at MMIO 0x5000c000 (irq = 18) is a Freescale MXC
mxcintuart.4: ttymxc4 at MMIO 0x5002c000 (irq = 40) is a Freescale MXC
brd: module loaded
loop: module loaded
FEC Ethernet Driver
PPP generic driver version 2.4.2
Linux video capture interface: v2.00
usbcore: registered new interface driver uvcvideo
USB Video Class driver (v0.1.0)
Driver 'sd' needs updating - please use bus_type methods
armadillo-nor: Found 1 x16 devices at 0x0 in 16-bit bank
  Intel/Sharp Extended Query Table at 0x010A
  Intel/Sharp Extended Query Table at 0x010A
  Intel/Sharp Extended Query Table at 0x010A
  Intel/Sharp Extended Query Table at 0x010A
  Intel/Sharp Extended Query Table at 0x010A
Using buffer write method
Using auto-unlock on power-up/resume
cfi_cmdset_0001: Erase suspend on write enabled
armadillo-nor: use default partitions(4)
Creating 4 MTD partitions on "armadillo-nor":
0x00000000-0x00020000 : "nor.bootloader"
0x00020000-0x00220000 : "nor.kernel"
0x00220000-0x00fe0000 : "nor.userland"
0x00fe0000-0x01000000 : "nor.config"
fsl-ehci fsl-ehci.0: Freescale On-Chip EHCI Host Controller
fsl-ehci fsl-ehci.0: new USB bus registered, assigned bus number 1
fsl-ehci fsl-ehci.0: irq 35, io mem 0x53ff4400
fsl-ehci fsl-ehci.0: USB 2.0 started, EHCI 1.00, driver 10 Dec 2004
usb usb1: configuration #1 chosen from 1 choice
hub 1-0:1.0: USB hub found
hub 1-0:1.0: 1 port detected
fsl-ehci fsl-ehci.1: Freescale On-Chip EHCI Host Controller
fsl-ehci fsl-ehci.1: new USB bus registered, assigned bus number 2
fsl-ehci fsl-ehci.1: irq 37, io mem 0x53ff4000
fsl-ehci fsl-ehci.1: USB 2.0 started, EHCI 1.00, driver 10 Dec 2004
usb usb2: configuration #1 chosen from 1 choice
hub 2-0:1.0: USB hub found
hub 2-0:1.0: 1 port detected

```



```

Initializing USB Mass Storage driver...
usbcore: registered new interface driver usb-storage
USB Mass Storage support registered.
input: gpio-keys as /devices/platform/gpio-keys.0/input/input0
rtc-s353xxa 1-0030: rtc core: registered rtc-s353xxa as rtc0
rtc-s353xxa: S-353XXA Real Time Clock class driver, (C) 2008 Atmark Techno, Inc.
i2c /dev entries driver
mxsdhci: MXC Secure Digital Host Controller Interface driver
mxsdhci: MXC SDHCI Controller Driver.
mmc0: SDHCI detect irq 159 irq 9 INTERNAL DMA
Registered led device: red
Registered led device: green
Registered led device: yellow
usbcore: registered new interface driver usbhid
usbhid: v2.6:USB HID core driver
Advanced Linux Sound Architecture Driver Version 1.0.16.
usbcore: registered new interface driver snd-usb-audio
usbcore: registered new interface driver snd-usb-caiaq
ASoC version 0.13.2
ALSA device list:
  No soundcards found.
ip_tables: (C) 2000-2006 Netfilter Core Team
TCP cubic registered
NET: Registered protocol family 17
NET: Registered protocol family 15
Static Power Management for Freescale i.MX25
rtc-s353xxa 1-0030: setting system clock to 2010-04-26 12:16:26 UTC (1272284186)
RAMDISK: ext2 filesystem found at block 0
RAMDISK: Loading 13410KiB [1 disk] into ram disk... done.
VFS: Mounted root (ext2 filesystem).
Freeing init memory: 128K
init started: BusyBox v1.00 (2010.04.26-09:15+0000) multi-call binary
Starting fsck for root filesystem.
fsck 1.25 (20-Sep-2001)
ext2fs_check_if_mount: No such file or directory while determining whether /dev/
ram0 is mounted.
/dev/ram0: clean, 938/1136 files, 12225/13410 blocks
Checking root filesystem: done
Remounting root rw: done
Mounting proc: done
Mounting usbfs: done
Mounting sysfs: done
Cleaning up system: done
Running local start scripts.
Starting udevd: done
Loading /etc/config: done
Changing file permissions: done
Configure /home/ftp: done
Starting syslogd: done
Starting klogd: done
Starting basic firewall: done
Setting hostname: done
Configuring network interfaces: udhcpc (v0.9.9-pre) started
fec: PHY @ 0x0, ID 0x0007c0f1 -- LAN8720
Sending discover...
eth0: link down
eth0: link up, 100Mbps, full-duplex
Sending discover...

```

```

Sending select for 172.16.2.130...
Lease of 172.16.2.130 obtained, lease time 86400
done
Starting inetd: done
Setting at-cgi: done
Starting lighttpd: done
Creating avahi.services: done
Starting avahi.daemon: done
Mounting ramfs /home/ftp/pub: done

atmark-dist v1.26.0 (AtmarkTechno/Armadillo-420)
Linux 2.6.26-at8 [armv5tejl arch]

armadillo420-0 login:
    
```

3.1 Boot Log

3.2. Login

The login prompt will be displayed once the boot has completed. The usernames shown in 3.1. Serial Console Login Username and Password can be used to login.

3.1 Serial Console Login Username and Password

Username	Password	Permissions
root	root	root user
guest	None	general user

3.3. Shutdown Method

To perform a safe shutdown, execute the command shown below, wait until the "The system is halted." message is displayed and then disconnect the power supply.

```

[armadillo ~]# halt
[armadillo ~]#
System is going down for system reboot now.

Starting local stop scripts.
Exiting Syslogd!
Syncing all filesystems:                               done
Unmounting all filesystems:                            done
The system is going down NOW !!
Sending SIGTERM to all processes.
The system is halted. Press Reset or turn off power
    
```

3.2 Shutdown Method

When not using removable storage, it is possible to perform a shutdown by just disconnecting the power supply.



Disconnecting the power supply while data is being written to removable storage may result in the filesystem or the data being damaged. Be sure to unmount removable storage first before disconnecting the power supply.

4. Network

This chapter explains the default network configuration and how to change this configuration, and also explains how to use the included network applications.

4.1. Default Network Connection Mechanisms

In its default state, the Armadillo is configured to have an IP address assigned to it automatically with either DHCP or Zeroconf so that it can connect to the network. The PC side network connection must also be configured so that it too correctly connects to the same network as the Armadillo.

4.1.1. DHCP Connections

When the Armadillo automatically connects to the network, it first attempts to use DHCP. When a DHCP server is present on the network, an IP address is assigned to the Armadillo by the DHCP server.

If the PC also uses DHCP in the same way, it will by default connect to the same network as the Armadillo.

4.1.2. Zeroconf Connections

If no DHCP server is found, the Armadillo uses a mechanism called Zeroconf (IPv4LL)^[1] to obtain an IP address.

Zeroconf uses an address from a specific range (169.254.0.1 - 169.254.255.254) with a subnet mask of 255.255.0.0. This IP address block is reserved by IANA (Internet Assigned Numbers Authority).

To connect with an Armadillo configured this way, the PC must connect to the same network. If Zeroconf is also used on the PC side, it of course can do so without problem.

If Zeroconf cannot be used on the PC side, it is also possible to perform the configuration required to connect to the Zeroconf network by using a static IP address. The PC can be made to connect to the same Zeroconf network by using an IP address from the 169.254.0.1 - 169.254.255.254 range with a subnet mask of 255.255.0.0.

While it is possible that a static IP address selected at random will overlap with the one selected by the Armadillo, this will not be a problem. As the Zeroconf on the Armadillo will detect transmission from another host using the same IP address and quickly change its own IP address, the Armadillo and PC will be able to differentiate each other after a brief period of time.

4.2. Changing Network Configuration

The following explains how to change the network settings on the Armadillo.



Please consult a network administrator for help with network connections.

^[1]Zeroconf is called Automatic Private IP Addressing (APIPA) in Windows.

4.2.1. Using a Web Browser to Change Network Configuration

It is possible to change the various network options using a Web browser. Refer to 4.4.7.4.2. AT Admin: System - Network for information on how to make the changes.

4.2.2. Logging In to Change Network Configuration

Boot-time network configuration can be changed by editing the appropriate file under `/etc/config` on the Armadillo and saving it to the config region. Refer to 9. Config Region - Configuration File Storage for details on saving to the config region.

4.2.2.1. Using a Static Address

In order to set the options shown in 4.1. Static IP Address Configuration Example, use the vi editor to change the content of the `/etc/config/interfaces` file in the same way as shown in 4.1. Static IP Address Configuration.

4.1 Static IP Address Configuration Example

Item	Configuration
IP Address	192.168.10.10
Netmask	255.255.255.0
Network Address	192.168.10.0
Broadcast Address	192.168.10.255
Default Gateway	192.168.10.1

```
[armadillo ~]# vi /etc/config/interfaces
# /etc/network/interfaces -- configuration file for ifup(8), ifdown(8) auto lo
eth0 iface lo inet loopback
iface eth0 inet static address 192.168.10.10 netmask 255.255.255.0 network
192.168.10.0 broadcast 192.168.10.255 gateway 192.168.10.1
```

4.1 Static IP Address Configuration

4.2.2.2. Using DHCP

In order to use DHCP, use the vi editor to change the content of the `/etc/config/interfaces` file in the same way as shown in 4.2. DHCP Configuration.

```
[armadillo ~]# vi /etc/config/interfaces# /etc/network/interfaces -- configuration
file for ifup(8), ifdown(8) auto lo eth0 iface lo inet loopback
iface eth0 inet dhcp
```

4.2 DHCP Configuration

4.2.2.3. Specifying A DNS Server

To specify a DNS server, use the vi editor to edit `/etc/config/resolv.conf`.

```
[armadillo ~]# vi /etc/config/resolv.conf
nameserver 192.168.10.1
```

4.3 DNS Server Configuration

4.2.3. Checking The Connection

The following shows how to check whether or not transmission is possible with the changed IP configuration.

First, enable the new configuration. This is not required if the settings were saved to the config region and the system rebooted.

```
[armadillo ~]# ifdown -a
[armadillo ~]# ifup -a
```

4.4 Enabling Configuration

Use ping to try to communicate with another host on the same network.

```
[armadillo ~]# ping 192.168.10.1
```

4.5 Ping Confirmation

4.3. Firewall

A simple firewall is enabled on the Armadillo. To display the current configuration, execute the command shown in 4.6. iptables.

```
[armadillo ~]# iptables --list
```

4.6 iptables

4.4. Network Applications

The following explains how to operate the network related applications included in the factory default userland.

4.4.1. Telnet

4.4.1.1. Telnet Server

It is possible to login from another PC via the network and perform remote operations. The username shown in 4.2. Username for Telnet Login can be used to login.

4.2 Username for Telnet Login

Username	Password
guest	None

4.4.1.2. Telnet Client

Telnet can be used to remotely login to another PC. To use telnet, execute the command as shown in 4.7. telnet.

```
[armadillo ~]# telnet [TELNET SERVER]
```

4.7 telnet

4.4.2. FTP

4.4.2.1. FTP Server

File transfers can be performed from another PC via the network. The username shown in 4.3. Username for FTP Login can be used to login.

4.3 Username for FTP Login

Username	Password
ftp	None

4.4.2.2. FTP Client

ftp can be used to transfer files with another PC. To use ftp, execute the command as shown in 4.8. ftp.

```
[armadillo ~]# ftp [FTP SERVER]
```

4.8 ftp

4.4.3. SSH

4.4.3.1. SSH Server

It is possible to login from another PC via the network and safely perform remote operations. The ssh server is set to not start automatically at boot time. To start the ssh server, execute the command as shown in 4.9. Starting sshd.

```
[armadillo ~]# sh /etc/init.d/sshd
```

4.9 Starting sshd



A public key is required in order to use sshd. This key will be generated automatically if it does not exist, a process which takes a number of minutes to perform.

For the username that can be used for login, refer to 4.4. Username for ssh Login.

4.4 Username for ssh Login

Username	Password
guest	None

4.4.3.2. SSH Client

ssh can be used to safely login to another PC. To use ssh, execute the command as shown in 4.10. ssh.

```
[armadillo ~]# ssh [USER]@[SSH SERVER]
```

4.10 ssh

4.4.4. Web Server

A Web server runs on the Armadillo. The Web server's top page will be displayed when the URL of the Armadillo ([http://\[Armadillo's IP address\]](http://[Armadillo's IP address]))^[2] is accessed from a Web browser.

4.4.5. NTP Client

The NTP (Network Time Protocol) client can be used to obtain time information from a time server. Execute the command as shown in 4.11. ntpclient.

```
[armadillo ~]# ntpclient -h [NTP SERVER] -s
36525 42052.288 32712.0 321.0 320195180072231.5 259.4 0
```

4.11 ntpclient

4.4.6. SMTP Client

The SMTP (Simple Mail Transfer Protocol) client can be used to send email. Execute the command shown in 4.12. mail.

```
[armadillo ~]# echo "[BODY]" | mail --subject="[TITLE]" --from="[FROM]" --smtp-
host=[SMTP SERVER] [TO]
```

4.12 mail



It will not be possible to send email if the current hostname is not specified in the /etc/hosts file. Execute the following command to check the current configuration.

```
[armadillo ~]# echo $HOSTNAME
armadillo420-0
[armadillo ~]# cat /etc/hosts
127.0.0.1 localhost
127.0.0.1 armadillo420-0

::1 localhost.v6
```

4.13 Hostname Configuration Confirmation

^[2]If the Armadillo's IP address is 192.168.10.10, then this will be <http://192.168.10.10/>.

4.4.7. at-cgi

It is possible to perform network configuration and firmware management from a Web browser.

4.4.7.1. AT Admin: Admin Screen

The top page of at-cgi as shown in 4.14. AT Admin: Overview will be displayed in the Web browser upon accessing [http://\[Armadillo's IP address\]/index.cgi](http://[Armadillo's IP address]/index.cgi).

The top page of at-cgi is AT Admin's "Overview." "Overview" and "System" are available in AT Admin.

Menu	Function
Overview	System Overview
System	System Configuration

These two functions are always displayed in the menu at the top of the page. Each one can be selected by clicking on the title.



4.14 AT Admin: Overview

4.4.7.2. AT Admin: Authorization

Authorization is required upon selecting "System" in AT Admin. A sub-window like that shown in 4.15. AT Admin: System Username / Password Authorization will be displayed at this time.

The default username and password are as shown below.

Username	Password
admin	admin

Enter the username and password and press the OK button. If authorization is successful, the selected screen will be displayed.

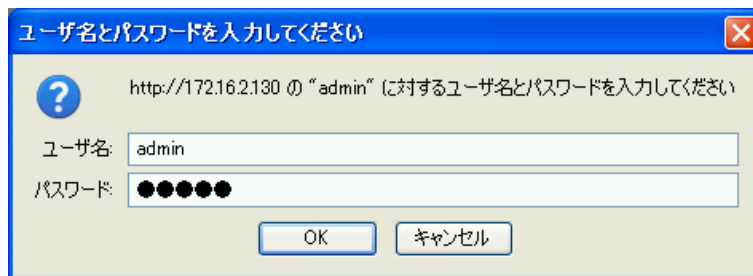

4.15 AT Admin: System Username / Password Authorization

4.4.7.3. AT Admin: Overview

The following explains each part of the Overview screen. Three main groups of information are displayed in the Overview.

- Network
- Uptime
- Firmware

4.4.7.3.1. Network

In Network, a summary of the current network configuration is displayed. The following three items are shown.

IP Address

The current IP address is shown here. When "(auto)" is displayed after the IP address, this indicates that an IP address has been automatically configured with either DHCP or Zeroconf. When "(static)" is displayed, this indicates that a static IP address has been set.

MAC Address

The assigned unique MAC address is shown here.

Host name

The configured hostname is shown here. This is armadillo420-0 by default.

4.4.7.3.2. Uptime

The time that has past since the Armadillo was booted is shown here. It is displayed as: days, hours, min, sec.

4.4.7.3.3. Firmware

The current firmware is displayed here.

Dist

The version and profile name of the distribution is shown here.

Kernel

The version of the Linux kernel is shown here.

4.4.7.4. AT Admin: System

4.4.7.4.1. AT Admin: System - System Overview

Configuration information related to the Armadillo can be checked on the System Overview. Three main groups of information are displayed here.

- Network Info
- System State
- Firmware

AT Admin

Overview System

System Overview Network Password Firmware Save & Load

Network Info

IP Address 172.16.2.130 (auto)
MAC Address 00:11:0C:11:00:03
Host name armadillo420-0
Traffic 505 packets received
 106 packets sent
Zeroconf Active

[show ifconfig](#)

System State

Load 0.00 (5min average)
Memory 61532K available, 37152K free
Uptime 0 days, 0 hours, 22 min, 15 sec

[show meminfo](#)
[show syslog](#)

Firmware

Version atmark-dist v1.25.0 (AtmarkTechno/Armadillo-420)
Kernel 2.6.26-at7

AT Admin version 1.64
 © 2006 Atmark Techno, Inc

4.16 AT Admin: System - System Overview

4.4.7.4.1.1. Network Info

Network configuration details are shown in Network Info.

IP Address

The current IP address is shown here. The meaning of the text displayed after the IP address is as shown below.

Text	Meaning
(auto)	Automatic IP address configuration with either DHCP or Zeroconf
(static)	Static IP address configuration

MAC Address

The unique MAC address assigned to the Armadillo is shown here.

Host name

The configured hostname is shown here. This is armadillo420-0 by default.

Traffic

The number of packets sent and received via the network since the system was booted is shown here.

Zeroconf

Whether Bonjour device detection is enabled or not is shown here.

It is possible to obtain more detailed network information from "show ifconfig." The Show ifconfig page displays the output of the ifconfig command as is. For details on the display content, refer to the ifconfig manual.

4.4.7.4.1.2. System State

It is possible to check the following three items related to the current system state.

Load

The system load state (Load Average) is shown here.

Memory

Memory usage state is shown here.

Uptime

The time that has past since the Armadillo was booted is shown here.

Also, with "show meminfo" and "show syslog," it is possible to check the state of the meminfo information and system log file as is.

4.4.7.4.1.3. Firmware

The current firmware is displayed here.

Dist

This is information on the distribution and current profile in use. The version and type of the userland (applications) software is shown here.

Kernel

The version of the Linux kernel is shown here.

4.4.7.4.2. AT Admin: System - Network

Changes to various network related configuration options can be carried out on the Network screen.

There are two main areas of configuration on the Network screen.

- IP Address
- Hostname

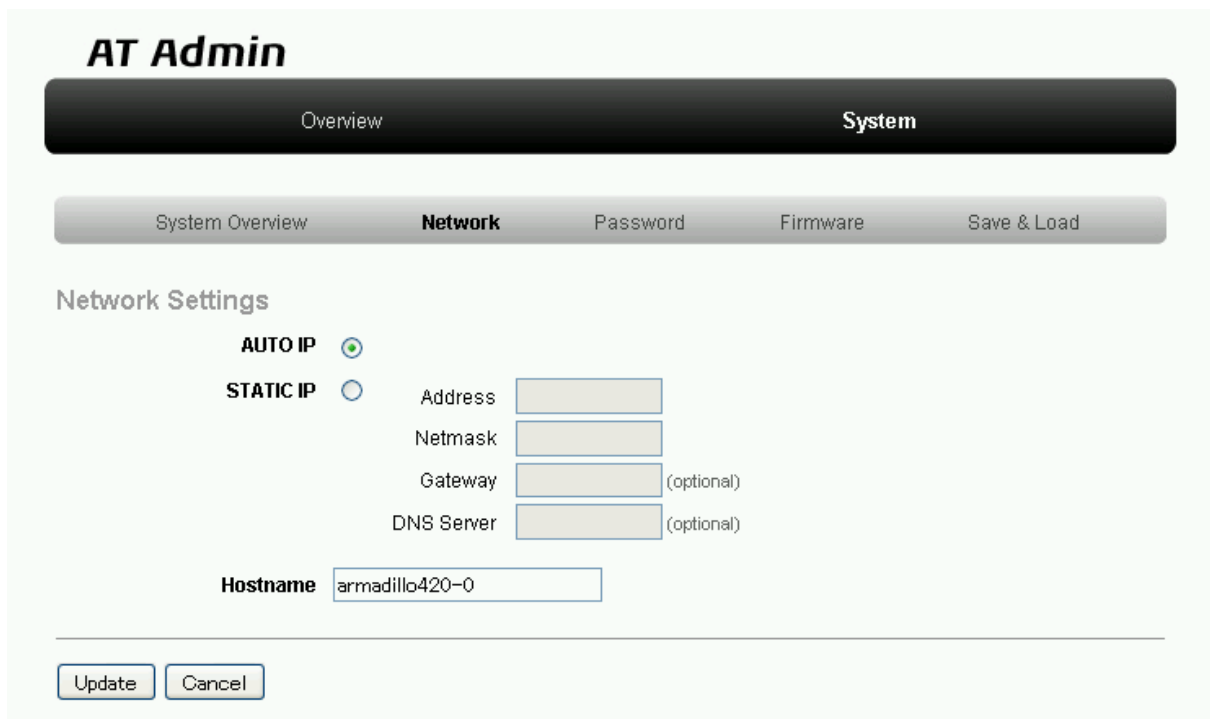

4.17 AT Admin: System - Network

4.4.7.4.2.1. IP Address

AUTO IP

Select to have an IP address acquired and set automatically. This is selected by default.

DHCP is used if a DHCP server is found on the network. If a DHCP server is not found, Zeroconf is used to automatically assign an address. For more details, refer to 4. Network.

STATIC IP

Select to set a static IP address.

The following details must be configured manually.

Address

Enter the IP address.

Netmask

Enter the subnet mask

Gateway

Enter the IP address of the gateway server. Leave it blank if a gateway is not being used.

DNS Server

Enter the IP address of a DNS (Domain Name System) server. Leave it blank if DNS is not being used.

4.4.7.4.2.2. Hostname

Changes to the hostname are made here. To change the hostname, enter the new name into the textbox. By default, this is set to "armadillo420-0." With Bonjour, this name is combined with the default network name ".local" to give the Armadillo the default name of "armadillo420-0.local." This name can be used with a Web browser. For more details, refer to 4.5.3. Bonjour Hostnames.

4.4.7.4.2.3. Update

After entering the changes, press the "Update" button and a screen similar to the following will be displayed after which the Armadillo will begin to operate with the new network configuration.



4.18 AT Admin: System - Network Update

The red LED on the Armadillo will activate while the network configuration is being updated and deactivate a few seconds later. After confirming that the LED has deactivated, access the top page on the Armadillo.



Just updating the network configuration does not save the changes.

In order to save the changes so that they remain in effect after the next boot, the configuration must be saved to flash memory. Refer to 4.4.7.4.5. AT Admin: System - Save & Load for information on saving.

4.4.7.4.3. AT Admin: System - Password

Changes to the username and password used for authorization of the Packet Scan and System screens can be made on the Password screen.

The screenshot displays the AT Admin web interface. At the top, there is a navigation bar with 'Overview' and 'System' tabs. Below this is a secondary navigation bar with 'System Overview', 'Network', 'Password', 'Firmware', and 'Save & Load' options. The 'Password' option is currently selected. The main content area is titled 'User and Password Details' and contains four input fields: 'Username' (with the value 'admin'), 'Current password' (masked with five dots), 'New password' (masked with five dots), and 'Confirm new password' (masked with five dots). At the bottom of the form are two buttons: 'Update' and 'Cancel'.

4.19 AT Admin: System - Password

4.4.7.4.3.1. User and Password Details

Username

Enter the administrator username. This is set to "admin" by default.

Current password

Enter the current password for confirmation. This is set to "admin" by default.

New password

Enter the new password.

Confirm new password

Enter the new password once more for confirmation.

4.4.7.4.3.2. Updating Userland and Password Configuration

After entering the changes, press the "Update" button to update the configuration.



Just updating the configuration does not save the changes. In order to save the changes so that they remain in effect after the next boot, the configuration must be saved to flash memory. Refer to 4.4.7.4.5. AT Admin: System - Save & Load for information on saving.

4.4.7.4.4. AT Admin: System - Firmware

The userland (applications) and Linux kernel firmware can be updated on the Firmware screen.

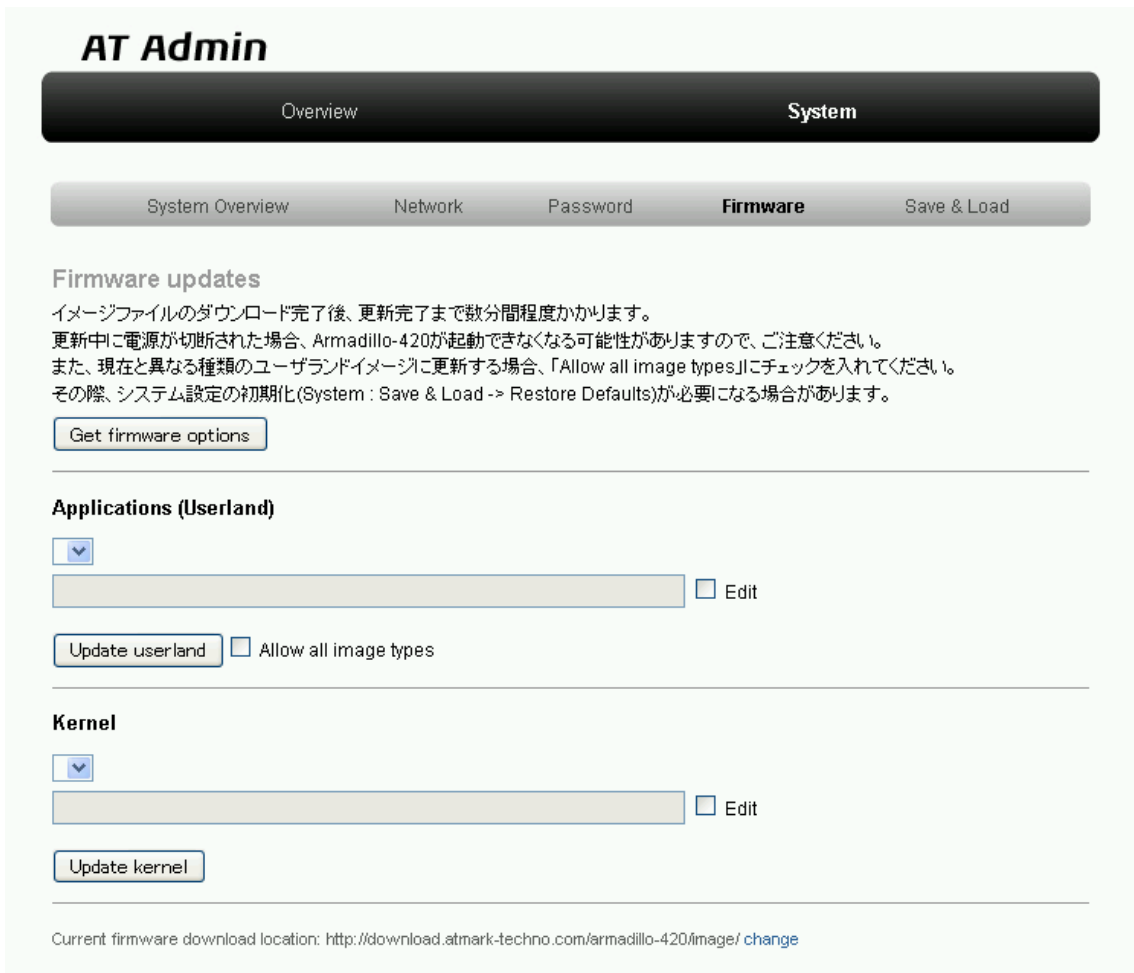

4.20 AT Admin: System - Firmware

To update to the image files available from the official web site^[3], first press the "Get firmware options" button. The available image files will be displayed in the "Applications (Userland)" and "Kernel" boxes.

^[3]A connection to the internet is required for this function.

4.4.7.4.4.1. Applications (Userland)

Userland (applications) updates are performed here.

Image Selection Box

Userland images available on the server are shown here. Select the preferred image.

URL Input Box

The URL of the userland image file to be downloaded is displayed here. A URL can be entered directly into this box by enabling the "Edit" checkbox to the right.



If the "Edit" checkbox is enabled, the path specified in the URL input box will be used and the image selected in the image selection box ignored.

Press the "Update userland" button and the userland image will be downloaded and written to flash memory. To update to a userland image model different to that of the current image, enable the "Allow all image types" checkbox before pressing the "Update userland" button.

4.4.7.4.4.2. Kernel

Linux kernel updates are performed here.

Image Selection Box

Kernel images available on the server are shown here. Select the preferred image.

URL Input Box

The URL of the Linux kernel image file to be downloaded is displayed here. A URL can be entered directly into this box by enabling the "Edit" checkbox to the right.



If the "Edit" checkbox is enabled, the path specified in the URL input box will be used and the image selected in the image selection box ignored.

Press the "Update kernel" button and the Linux kernel image will be downloaded and written to flash memory.

4.4.7.4.4.3. Image Updates

After pressing "Update userland" or "Update kernel," 4.21. AT Admin: System - Updating Firmware will be displayed.



4.21 AT Admin: System - Updating Firmware

Do not disconnect the Armadillo's power supply while the firmware is being updated. If the power is disconnected before the update completes, the Armadillo may no longer boot correctly.

Once the update has completed, the Firmware screen shown in 4.20. AT Admin: System - Firmware will be displayed. To update another image, make the necessary selections and press the relevant update button again.

After updating to a different type of firmware the configuration files must be initialized. For information on the initialization of configuration files, refer to 4.4.7.4.5. AT Admin: System - Save & Load.

After all updates have been completed, reboot the Armadillo to start using the new firmware. Refer to 4.4.7.4.5. AT Admin: System - Save & Load for information on rebooting from AT Admin.

4.4.7.4.5. AT Admin: System - Save & Load

System configuration can be saved to flash memory, reloaded or initialized, and the system rebooted on the Save & Load screen.



4.22 AT Admin: System - Save & Load

4.4.7.4.5.1. Save & Load System Settings

System configuration can be saved to flash memory or loaded here.

Save current configuration to flash memory (Save)

Save configuration such as that set in "Network Settings" and "Password" to flash memory. The saved configuration will remain in effect even after the Armadillo is rebooted.

Discard current system configuration and load the configuration saved in flash memory (Reload)

Discard the current configuration and restore the configuration saved in flash memory to return to the previous state. After a screen similar to that shown below is displayed, the Armadillo will begin to operate with the new (that read from flash memory) network configuration.



4.23 AT Admin: System - Reload

If the network connection is changed as a result of restoring the previous configuration, the red LED on the Armadillo will activate. After confirming that the LED has deactivated, access the top page on the Armadillo.

Discard current system configuration and load the default configuration (Restore Defaults)

Discard the current configuration and restore the default configuration for the currently running firmware. The configuration saved in flash memory will also be initialized.

4.4.7.4.5.2. System Reboot

The system can be rebooted here.

Reboot the system (Reboot)

This reboots the Armadillo. Approximately 10 seconds after 4.24. AT Admin: System - Reboot is displayed, the Armadillo will shutdown and then restart.



4.24 AT Admin: System - Reboot

After rebooting, if the network connection has changed the red LED on the Armadillo will activate for anywhere between 10 seconds to a number of minutes. After confirming that the LED has deactivated, access the top page on the Armadillo again.

4.5. Using Bonjour

As Armadillo supports Bonjour, it is possible to easily find an Armadillo from a PC which also supports Bonjour and is on the same network.^[4]

(Quoted from Apple Inc.'s web site)

About "Bonjour"

Bonjour, also called zero configuration networking, is a service to automatically discover computers, devices and services on IP networks. As the world standard IP protocol is used in Bonjour, devices can automatically detect each other without the need to enter IP addresses or configure a DNS server.

4.5.1. Installing Bonjour

4.5.1.1. Windows

Bonjour for Windows must be installed to use Bonjour on Windows. As third-party distribution of this software is not permitted, it is not included in the development set. Please download it from Apple Inc.'s web site.

Apple - Support - Downloads - Bonjour for Windows

^[4]The automatic IP address acquisition functionality of the operating system is normally used for the network configuration on the PC side. Refer to 4.1. Default Network Connection Mechanisms for more details.

Execute the downloaded BonjourSetup.exe file and follow the instructions on the screen to install the software.

4.5.1.2. Mac OS X

Bonjour is a standard feature of Mac OS X

4.5.1.3. Linux

Bonjour can be used on Linux by utilizing Avahi and the nss-mdns library. Please refer to your distribution's documentation for more information.

4.5.2. Operational Check

The following demonstrates how to find an Armadillo using Bonjour in a Windows environment. For other operating systems, please refer to the relevant manuals for that environment.

Start Internet Explorer on the Windows PC.

If Bonjour has been installed, it can be displayed in the Explorer Bar in Internet Explorer (IE). From the menu bar, enable "View (V)" --> "Explorer Bar (E)" --> "Bonjour."



4.25 Internet Explorer Explorer Bar Configuration

Check the contents of the "Bonjour" Explorer Bar on the left side of IE.



4.26 "Bonjour" Explorer Bar

The first line is a link to a description of Bonjour on Apple Inc.'s web site.

Below that, the links listed in 4.5. Armadillo-420 Bonjour Links will be displayed. These are links to servers running on the Armadillo.

4.5 Armadillo-420 Bonjour Links

Display	Link Destination
AT Admin on armadillo420-X [00:11:0C:XX:XX:XX]	Link to at-cgi top page
http on armadillo420-X [00:11:0C:XX:XX:XX]	Link to Web server top page

Display	Link Destination	
Camera on armadillo420-X [00:11:0C:XX:XX:XX]	Link to video server top page	

Double clicking "http on armadillo420-X [00:11:0C:XX:XX:XX]" will display the top page of the web server in the browser.

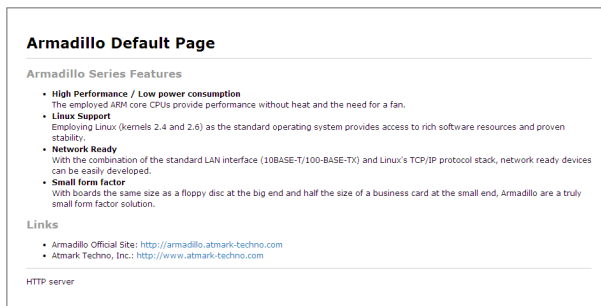

4.27 Web Server Top Page

Double clicking "AT Admin on armadillo420-X [00:11:0C:XX:XX:XX]" will display the top page of at-cgi in the browser. Refer to 4.4.7. at-cgi for more details.

Double clicking "Camera on armadillo420-X [00:11:0C:XX:XX:XX]" when an UVC compatible Web camera is connected to the Armadillo-420 will display the top page of the video server in the browser. Refer to 7.4. UVC Compatible Web Cameras for more details.

If "http on armadillo420 [00:11:0C:XX:XX:XX]" is not displayed in the Explorer Bar, please refer to 10.2. The Armadillo Cannot Be Found With Bonjour. If "AT Admin" is not displayed, please correctly configure the PC side network settings by referring to 4.1. Default Network Connection Mechanisms.

4.5.3. Bonjour Hostnames

The hostname shown with Bonjour will be the same as the hostname configured on the Armadillo (this is set to armadillo420-0 by default). As the Bonjour network name is ".local," the URL opened with Bonjour in the web browser will normally be http://armadillo420-0.local/.

However, if two or more hosts with the same hostnames exist on the same network (like when multiple Armadillo are connected in their default state), the number at the end of the hostname will change from the second host onwards. For example, with Armadillo in their default state, the second hostname would be "http://armadillo420-1.local/" and the third "http://armadillo420-2.local/." Please note that in this situation the hostname (as configured in "AT Admin") of the second host onwards will not match its Bonjour hostname.

In this situation, the MAC address can be used to identify each individual unit. The MAC address displayed in the Internet Explorer Bonjour list can be compared with the sticker attached to each unit. Refer to 4.26. "Bonjour" Explorer Bar.

5. Storage

5.1. Devices Which Can Be Used As Storage

The devices shown in 5.1. Storage Devices can be used as storage on Armadillo-420.

5.1 Storage Devices

Device Type	Disk Device	First Partition
USB Flash Memory	/dev/sd*	/dev/sd*1
microMMC / microSD Cards	/dev/mmcblk*	/dev/mmcblk*p1

5.2. Storage Initialization and Mounting

Using a microSD card as an example, the following explains how to initialize and mount storage.

5.2.1. Disk Initialization

Make one partition on the microSD card.

```
[armadillo ~]# fdisk /dev/mmcblk0

Command (m for help): d
No partition is defined yet!

Command (m for help): n
Command action
  e   extended
  p   primary partition (1-4)
P
Partition number (1-4): 1
First cylinder (1-7375, default 1):
Using default value 1
Last cylinder or +size or +sizeM or +sizeK (1-7375, default 7375):
Using default value 7375

Command (m for help): p

Disk /dev/mmcblk0: 1004 MB, 1004535808 bytes
7 heads, 38 sectors/track, 7375 cylinders
Units = cylinders of 266 * 512 = 136192 bytes

   Device Boot      Start         End      Blocks   Id  System
/dev/mmcblk0p1                1         7375        980856   83  Linux

Command (m for help): w
The partition table has been altered!

Calling ioctl() to re-read partition table.
mmcblk0: p1
```

```
mmcblk0: p1
Syncing disks.
```

5.1 Disk Initialization Method

5.2.2. Filesystem Creation

Create a filesystem on the newly initialized disk partition. Here, an ext3 filesystem is created on partition one of the microSD card (/dev/mmcblk0p1).

```
[armadillo ~]# mke2fs -j /dev/mmcblk0p1
mke2fs 1.25 (20-Sep-2001)
Filesystem label=
OS type: Linux
Block size=4096 (log=2)
Fragment size=4096 (log=2)
122624 inodes, 245214 blocks
12260 blocks (4%) reserved for the super user
First data block=0
8 block groups
32768 blocks per group, 32768 fragments per group
15328 inodes per group
Superblock backups stored on blocks:
    32768, 98304, 163840, 229376

Writing inode tables: done
Creating journal (4096 blocks): done
Writing superblocks and filesystem accounting information: done

This filesystem will be automatically checked every 34 mounts or
180.00 days, whichever comes first. Use tune2fs -c or -i to override.
```

5.2 Filesystem Creation

5.2.3. Mounting

After creating the ext3 filesystem at /dev/mmcblk0p1 it can be mounted at /mnt by executing the command as shown in 5.3. Mount Method.

```
[armadillo ~]# mount -t ext3 /dev/mmcblk0p1 /mnt
```

5.3 Mount Method

5.3. Storage Operational Check

Using a microSD card as an example, the following explains how to perform an operational check of storage. The steps in 5.2. Storage Initialization and Mounting must have been performed first.

5.3.1. Writing Data

Write data to the storage. The command below copies the busybox executable file to storage.

```
[armadillo ~]# cp /bin/busybox /mnt/
```

5.4 Writing Data To Storage

To ensure that the data is written to storage, unmount and then remount the storage.

```
[armadillo ~]# umount /mnt  
[armadillo ~]# mount -t ext3 /dev/mmcblk0p1 /mnt
```

5.5 Writing Data To Storage

5.3.2. Checking Data

Check the data previously written to storage. If executing the commands below produces the same MD5 checksums for both `/bin/busybox` and `/mnt/busybox`, then this confirms that the storage is operating correctly.

```
[armadillo ~]# md5sum /bin/busybox  
124f7023cd7714b2ac15ae4e0a735244 /bin/busybox  
[armadillo ~]# md5sum /mnt/busybox  
124f7023cd7714b2ac15ae4e0a735244 /mnt/busybox
```

5.6 Storage Data Check

6. Input Devices

This chapter explains how to receive events from input devices. On Armadillo-420, the buttons are supported as input devices. For the specifications of the button driver, refer to the "Buttons" chapter in the "Armadillo-400 Series Software Manual."

6.1. evtest

The evtest command can be used to check what kind of input events are occurring. evtest is used as shown in 6.1. evtest Command Format.

```
[armadillo ~]# evtest /dev/input/eventX
```

6.1 evtest Command Format

For the device file to specify in place of /dev/input/eventX, refer to 6.1. Input Device Files.

6.1 Input Device Files

Device File	Device
/dev/input/event0	Buttons



The event device file numbers are determined by the order the input devices are detected. Therefore, if another input device such as a USB keyboard is detected at boot time, the event device numbers may change.

Enter Ctrl + C to stop evtest.

6.2. swmgr

The swmgr command can be used to execute another command when a button is pressed.

swmgr is used as shown in 6.2. swmgr Command Format.

```
[armadillo ~]# swmgr [BUTTON] [LOOP] [COMMAND]
```

6.2 swmgr Command Format

Specify the button to receive events from in place of BUTTON. For supported buttons, refer to 6.2. Buttons Supported By swmgr.

6.2 Buttons Supported By swmgr

Buttons	Description
sw0	SW1

Specify the number of times to wait for an event in place of LOOP. Specify 0 for an unlimited number of times.

Specify the operation to execute when an event occurs in place of COMMAND.

6.3. swmgr Example

To display time information when SW1 is pressed, execute the command as shown in 6.3. swmgr Example 1.

```
[armadillo ~]# swmgr sw0 1 date
```

6.3 swmgr Example 1

7. Other Devices

7.1. LED

The Armadillo-400 Series LEDs are supported as LED class devices. The LEDs can be controlled with the files under the LED class directories. For the LED class directories and corresponding LEDs, refer to 7.1. LEDs and LED Class Directories.

7.1 LEDs and LED Class Directories

LED Class Directory	Description
/sys/class/leds/red/	LED3 (red)
/sys/class/leds/green/	LED4 (green)
/sys/class/leds/yellow/	LED5 (yellow)

7.1.1. Activating and Deactivating LEDs

LEDs can be turned on and off by writing an appropriate value to the brightness file under the LED class directory. A value between 0 and 255 can be written to the brightness file.

Writing any value apart from 0 to the brightness file turns the LED on. As the Armadillo-400 Series LEDs do not have brightness control functionality, the value has no effective meaning.

```
[armadillo ~]# echo 1 > /sys/class/leds/yellow/brightness
```

7.1 Turning LED5 On

Writing 0 to the brightness file turns the LED off.

```
[armadillo ~]# echo 0 > /sys/class/leds/yellow/brightness
```

7.2 Turning LED5 Off

The current state of the LED can be obtained by reading the brightness file. 0 represents the off state, and any other value represents an on state.

```
[armadillo ~]# cat /sys/class/leds/yellow/brightness  
0
```

7.3 Displaying LED5 State

7.1.2. Using Triggers

A trigger to turn the LED on and off can be set by writing an appropriate value to the trigger file under the LED class directory. For values supported by the trigger file, refer to 7.1. LEDs and LED Class Directories.

7.2 trigger Configuration

Configuration	Description
none	No trigger is set.
mmc0	LED acts as microSD card access lamp.
timer	Blink on and off at certain intervals. After setting this trigger, delay_on and delay_off files appear under the LED class directory which can be used to set the on and off times in millisecond increments.
heartbeat	Blink on and off like a heart beat.
default-on	Used mainly from the kernel. The LED is turned on at boot time.

Executing the commands below will cause LED3 to repeatedly turn on for 1 second and then off for 500 milliseconds.

```
[armadillo ~]# echo timer > /sys/class/leds/red/trigger
[armadillo ~]# echo 1000 > /sys/class/leds/red/delay_on
[armadillo ~]# echo 500 > /sys/class/leds/red/delay_off
```

7.4 Specifying timer As Trigger For LED3

The current trigger of the LED can be obtained by reading the trigger file. The value enclosed in [] is the current trigger.

```
[armadillo ~]# cat /sys/class/leds/yellow/trigger
[none] mmc0 timer heartbeat default-on
```

7.5 Displaying LED3 Timer

7.2. GPIO

The Armadillo-400 Series GPIO are supported as GPIO class devices. The GPIO can be controlled with the files under the GPIO class directories. For the GPIO class directories and corresponding GPIO, refer to 7.3. GPIO and GPIO Class Directories.

7.3 GPIO and GPIO Class Directories

GPIO Class Directory	Description
/sys/class/gpio/CON9_1/	CON9 pin 1
/sys/class/gpio/CON9_2/	CON9 pin 2
/sys/class/gpio/CON9_11/	CON9 pin 11
/sys/class/gpio/CON9_12/	CON9 pin 12
/sys/class/gpio/CON9_13/	CON9 pin 13
/sys/class/gpio/CON9_14/	CON9 pin 14
/sys/class/gpio/CON9_15/	CON9 pin 15
/sys/class/gpio/CON9_16/	CON9 pin 16
/sys/class/gpio/CON9_17/	CON9 pin 17
/sys/class/gpio/CON9_18/	CON9 pin 18
/sys/class/gpio/CON9_21/	CON9 pin 21
/sys/class/gpio/CON9_22/	CON9 pin 22
/sys/class/gpio/CON9_23/	CON9 pin 23
/sys/class/gpio/CON9_24/	CON9 pin 24

GPIO Class Directory	Description
/sys/class/gpio/CON9_25/	CON9 pin 25
/sys/class/gpio/CON9_26/	CON9 pin 26
/sys/class/gpio/CON9_27/	CON9 pin 27
/sys/class/gpio/CON9_28/	CON9 pin 28

7.2.1. Changing I/O Direction

The I/O direction can be changed by writing an appropriate value to the direction file under the GPIO class directory. For values supported by the direction file, refer to 7.4. direction Configuration.

7.4 direction Configuration

Configuration	Description
high	Set I/O direction to OUTPUT. The input level can be obtained and set in this state. The input level will be HIGH.
out	Set I/O direction to OUTPUT. The input level can be obtained and set in this state. The input level will be LOW.
low	This is the same as setting "out".
in	Set I/O direction to INPUT. The input level can be obtained but not set in this state.

7.2.2. Obtaining Input Level

The input level can be obtained by reading the value file under the GPIO class directory. 0 represents a LOW level and 1 a HIGH level. The input level can be obtained both when the I/O direction is set to INPUT and OUTPUT.

```
[armadillo ~]# cat /sys/devices/virtual/gpio/CON9_1/value
0
```

7.6 Obtaining CON9_1 Input Level

7.2.3. Configuring Output Level

The output level can be set by writing an appropriate value to the value file under the GPIO directory. 0 represents a LOW level and 1 a HIGH level. Output level configuration can only be carried out when the I/O direction is set to OUTPUT.

```
[armadillo ~]# echo 1 > /sys/devices/virtual/gpio/CON9_2/value
```

7.7 Configuring CON9_2 Output Level

7.3. RTC

As the RTC Option Module is connected by default in the Armadillo-420 Basic Model Development Set, time information can be maintained even after disconnecting power by using the RTC (calendar clock) function.

To set time information to the RTC, first set the system clock. After that, then set the hardware clock (RTC) to match the system clock.

7.3.1. Setting System Clock With date

The time format used as an argument to the date command is: MMDDhhmmCCYY.ss. In the example below, the date and time are set to 1/23/2000 4:56:00.

```
[armadillo ~]#date Displays the current system clock
[armadillo ~]#date 012304562000.00
[armadillo ~]#date
Check that the system clock was set correctly
```

7.3.2. Setting System Clock With NTP Client

The system clock can be set using the NTP client. For more information, refer to 4.4.5. NTP Client.

7.3.3. Setting Hardware Clock

```
[armadillo ~]#hwclock Displays the hardware clock
[armadillo ~]#hwclock --utc --systemc Sets hardware clock in UTC
[armadillo ~]#hwclock
Check that the hardware clock was set correctly
```

7.4. UVC Compatible Web Cameras

UVC (USB Video Class) compatible Web cameras can be used with the Armadillo-400 Series.^[1]

With the default image on the Armadillo-420 Basic Model Development Set, when a UVC compatible Web camera is connected, the video server starts automatically and the video recorded by the camera can be viewed from a browser.

MJPEG-streamer is used as the video server, and is started by udev when a Web camera is connected. LED3 (red) will blink while MJPG-streamer is running.

While LED3 (red) is blinking, the MJPG-Streamer demo page can be displayed by accessing [http://\(Armadillo-420's IP address\):8080/](http://(Armadillo-420's IP address):8080/) in a Web browser.

^[1]For information on devices tested with the Armadillo-400 Series, refer to the tested devices page (<http://armadillo.atmark-techno.com/tested-devices>) on the Armadillo Developers Site.

MJPG-Streamer
Demo Pages
a ressource friendly
streaming application

Home
Static

Stream

Java
Javascript
Control

Version info:
v0.1 (Okt 22, 2007)

Stream

Display the stream

Hints

This example shows a stream. It works with a few browsers like Firefox for example. To see a simple example click [here](#). You may have to reload this page by pressing F5 one or more times.

Source snippet

```

```



© The **MJPG-streamer team** | Design by **Andreas Viklund**

7.8 MJPG-Streamer Demo Page



The Java runtime must be installed on the PC being used in order to run the Java sample. Also, an appropriate codec must be installed on the PC in order to display the Stream in Internet Explorer.

8. Boot Modes and Bootloader Functions

This chapter explains about the boot modes on the Armadillo-400 Series and also about the boot configuration functions of Hermit-At, the default bootloader.

JP1 can be used to select between the on-board flash memory boot mode and the UART boot mode on the Armadillo-400 Series. In the on-board flash memory boot mode, the bootloader stored in the bootloader region of flash memory is booted. The UART boot mode is used for system restore when, for example, the bootloader stored in flash memory has been damaged. For more information, refer to "Restoring Bootloader to Factory State" in the "Armadillo-400 Series Software Manual."

8.1. Boot Mode Selection

In on-board flash memory boot mode, the bootloader stored in the bootloader region of flash memory is executed at power on.

With the default bootloader (Hermit-At), JP2 is used to select between auto boot mode, where the kernel is automatically booted, and maintenance mode, where it is possible to carry out various configuration.

Each boot mode is detailed in 8.1. Boot Modes.

8.1 Boot Modes

Mode	JP2	Description
Auto-boot	Open	The Linux kernel is automatically booted after power on.
Maintenance	Short	The Hermit-At command prompt that can be used for changing configuration is started.

8.2. Linux Kernel Boot Option Configuration

Various settings including console and root filesystem settings can be changed by specifying the appropriate Linux kernel boot options. The following details some options typically used with Armadillo.

The setenv function of Hermit-At is used for this configuration. Parameters set with setenv are saved to flash memory and remain in effect even after rebooting.

The clearenv command is used to clear any set parameters.

```
hermit> clearenv
```

8.1 Linux Kernel Boot Option Clear

8.2.1. Console Configuration

To change the output console of the boot log, set the console parameter as shown below.

```
hermit> setenv console=ttymxc1
```

8.2 Console Designation

For the effects on logging for each setting, refer to 8.2. Console Configuration Effect On Output Destination.

8.2 Console Configuration Effect On Output Destination

Console Option	Boot Log Output Destination	Maintenance Mode Prompt Destination ^[1]
ttymxc1	CON3 (Serial Interface 1)	CON3 (Serial Interface 1)
ttymxc2	CON9 (Serial Interface 2)	CON9 (Serial Interface 2)
ttymxc4	CON9 (Serial Interface 3)	CON9 (Serial Interface 3)
null	None	CON3 (Serial Interface 1)
Other (tty1 etc)	The specified console ^[2]	CON3 (Serial Interface 1)

^[1]Effective from next boot.

^[2]No log output from bootloader.



If the kernel console is set with setenv, this configuration is also carried over to the Hermit-At console.

For example, if the kernel console is set to ttymxc2, the Hermit-At console will also change to ttymxc2 from the next boot.

8.2.2. Specifying Image File To Boot

On the Armadillo-400 Series, in addition to on-board flash memory it is also possible to boot an image file from storage or a tftp server. For more information, refer to "Kernel and Userland Placement" in the "Armadillo-400 Series Software Manual."

8.2.3. Other Boot Options

There are a large number of options available aside from those introduced here. For more information refer to a book on the Linux kernel or the documentation included in the Linux kernel source code (kernel-source/Documentation/kernel-parameters.txt).

8.2.4. Boot Option Configuration Examples

- To set the console to Serial Interface 2

```
hermit> setenv console=ttymxc2
```

8.3 Boot Option Configuration Example 1

9. Config Region - Configuration File Storage

The config region is a flash memory region used to save files in order to maintain data even after hardware resets. The `flatfsd` command is used to write data to and read data from the config region.

9.1. Reading From The Config Region

The command shown below is used to read from the config region. The files read from the config region are created under the `/etc/config` directory.

```
[armadillo ~]# flatfsd -r
```

9.1 Reading From The Config Region



In the default software, the files are automatically read out from the config region at boot time. If the config region data has been damaged, it is replaced with the contents of the `/etc/default` directory.

9.2. Saving To The Config Region

The command shown below is used to save to the config region. The files saved to the config region are those present under the `/etc/config` directory.

```
[armadillo ~]# flatfsd -s
```

9.2 Saving To The Config Region



If the save to the config region is not carried out, then changes to the files under the `/etc/config` directory will be lost when power is cut.

9.3. Initializing The Config Region

The command shown below is used to initialize the config region. On initialization, the files under the `/etc/default` directory are saved to the config region and are then also reproduced under the `/etc/config` directory.

```
[armadillo ~]# flatfsd -w
```

9.3 Config Region Initialization

10. Troubleshooting

10.1. The Armadillo Will Not Boot

- Please check that the green LED turns on after connecting power. If it does not turn on, please check that the power supply is properly connected.

10.2. The Armadillo Cannot Be Found With Bonjour

- Please check that the LAN Link LED is on. If it is not on, please ensure that the LAN cable is inserted correctly.
- Please ensure that there is no router between the PC with Bonjour and the Armadillo. The Armadillo cannot be found if a router exists between the two.
- If a firewall is active, please ensure that the port "UDP 5353" used by Bonjour is accessible.

10.3. The Screen Does Not Display After Changing The Network Configuration

- A change in the IP address, for example when changing from AUTO IP to a STATIC IP configuration, means that the correct current IP address corresponding to the hostname also changes. However, depending on the WEB browser, the cached old IP address may continue to be used and pages accessed via the hostname will not be displayed for a certain period of time. If this occurs, please close and restart the WEB browser and then access the top page again.



Restarting the browser has been confirmed to alleviate the problem with Internet Explorer Version 6.

- If the screen does not display even after carrying out the procedure described above, it may indicate that the Armadillo's network connection is in an irregular state. As the changes to the network configuration have not yet been saved to flash memory at this point, just reboot the Armadillo and then redo the network configuration.

1.0.0	04/28/2010	<ul style="list-style-type: none">• Initial Release
1.0.1	08/20/2010	<ul style="list-style-type: none">• Made correction to RS232C level conversion adaptor connection method in 2.1. Layout Diagram

Armadillo-420 Basic Model Development Set Startup Guide
Version 1.0.1
2010/11/05

Atmark Techno, Inc.

060-0035 AFT Bldg. 6F, N5E2, Chuo-ku, Sapporo TEL 011-207-6550 FAX 011-207-6570
