

To CON8 of Armadillo-300

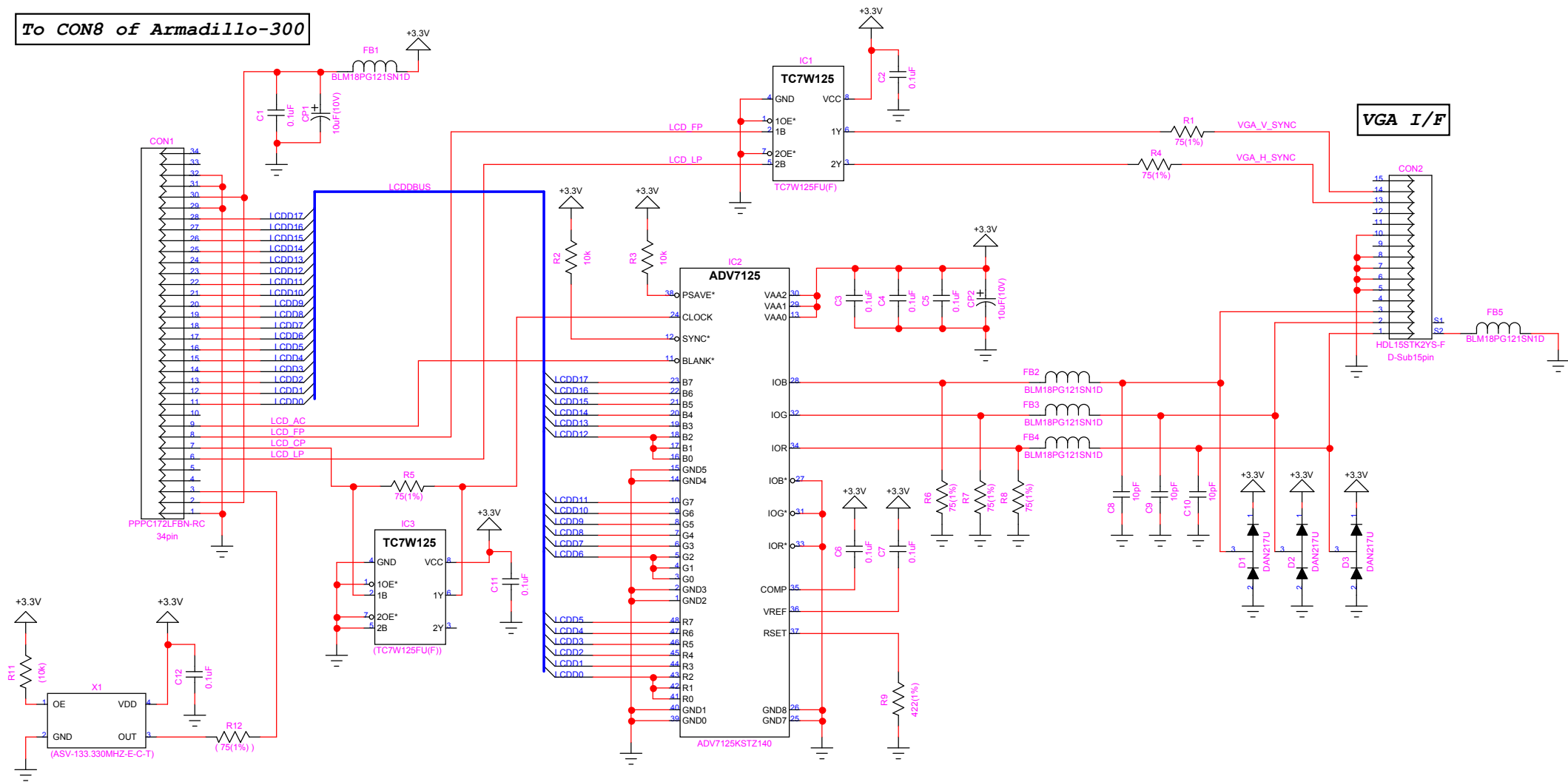

To JP1 of Armadillo-300

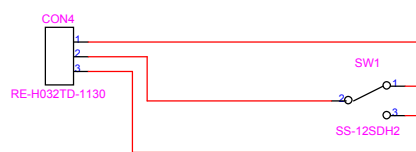

To CON7 of Armadillo-300

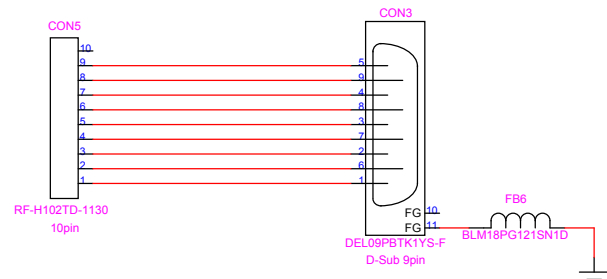

Power LED

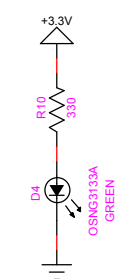

Atmark Techno, Inc.	
Title	: Armadillo-300 VGA Board
Board ID	: At-NSVI0901
Page	: 1/1
Rev.	: A
Date	: 2007/03/08